

GUILLOTINE VALVES

T-TAPPI SERIES

18/11/2019

UNIDIRECTIONAL Guillotine Valve

- Unidirectional "LUG" guillotine valve.
- Monobloc cast body with interior slides for optimum movement of the gate during operation.
- Provides high flow rates with low pressure drop.
- Various seat and packing materials available.
- Face-to-face dimension in accordance with MSS-SP-81 standard.
- Has an arrow on the body indicating the flow direction.

General Applications:

- This guillotine valve is suitable to work with liquids with a maximum concentration of solids of 6%. If used for solids, we recommend installing with the body which indicates the contrary flow direction:
- Bulk transport - Draining plants - Paper industry
- Water treatment - Chemical plants - Food sector
- Mining

Sizes: ND50 - 2" to ND1200 - 48"
(larger sizes on request).

Work (ΔP):	ND50-2" to ND600-24" 10 kg/cm ²	
	ND700-28" to ND900-36" 8 kg/cm ²	
	ND1000-40" to ND1200-48" 4 kg/cm ²	

- The mentioned working pressures are just valid for the pressures applied on the direction of the arrow market on the body. As the valve is designed with gate support guides, the valves are able to support a 30% of these pressures from the opposite direction without any damage on them. In these cases, the valves are not 100% water tight. To obtain total water tightness in these conditions, it is necessary to incorporate additional supports.

Drilling: DIN PN10 and ANSI B16.5 (150 LB)

Other common flanges:	DIN PN 16	JIS standard	Australian standard
	DIN PN 6	DIN PN25	British standard

Directives:

- Machinery Directive: **DIR 2006/42/EC (MACHINERY)**
- Pressure Equipment Directive: **DIR 97/23/EC (PED) ART.3, P.3**
- Potentially Explosive Atmospheres Directive (optional): **DIR 94/9/EC (ATEX) CAT.3 ZONE 2 and 22 GD** , for information on categories and zones please contact **C.M.O.** Technical-Sales Department.

Quality dossier:

- All valves are tested hydrostatically at **C.M.O.** and material and test certificates can be provided.
- Body test = working pressure x 1.5.
- Seat test = working pressure x 1.1.

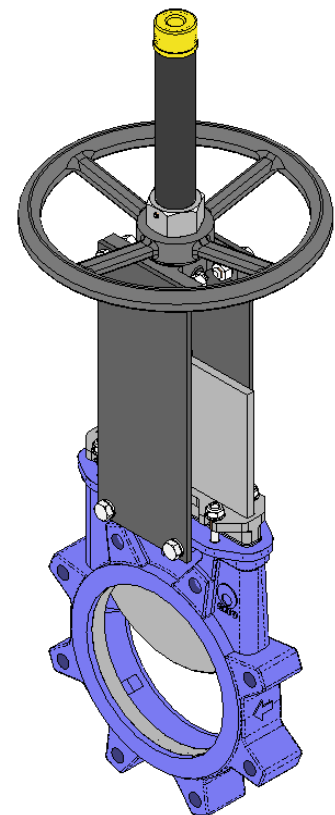

fig. 1

C.M.O.

GUILLOTINE VALVES

T-TAPPI SERIES

Advantages of C.M.O. "Model T-TAPPI"

When a knife gate valve remains open for long periods of time and the body's internal walls are parallel a very large torque is required to close it. The inside of the **T-TAPPI** body is conically shaped, providing greater space. This way, when the valve is closed the solids stored inside it can be easily removed.

This valve is defined as unidirectional and in this type of valves of other suppliers there is the risk of the gate bending due to the existence of counterpressure. This cannot happen with the **C.M.O.** valve because it contains internal slides that support the knife gate and allow it to work under counter-pressure of 30% of the maximum working pressure, without the knife gate becoming deformed.

The stem protection hood is independent from the handwheel securing nut, this means the hood can be disassembled without the need to release the handwheel. This advantage allows regular maintenance operations to be performed, such as lubricating the stem, etc.

The **C.M.O.** valve stem is made from stainless steel 18/8. This is another additional benefit, since some manufacturers supply it with 13% chrome, which quickly rusts.

The operating wheel is manufactured in nodular cast GJS-500. Some manufacturers supply it in common cast-iron, which can lead to breakage in the event of very high operation torque or a bang. The yoke is has a compact design with the bronze actuator nut protected in a sealed and lubricated box. This makes it possible to move the valve with a key, even without the handwheel (in other manufacturers' products this is not possible).

The pneumatic actuator's upper and lower covers are made of GJS-400 nodular cast iron, making them highly shock resistant. This characteristic is essential in pneumatic actuators.

The pneumatic cylinder's seals are commercial products and can be purchased worldwide. This means it is not necessary to contact **C.M.O.** every time a seal is required.

STANDARD COMPONENTS LIST		
COMPONENT	STEEL VERSION	STAINLESS STEEL VERSION
1- Body	A216WCB	CF8M
2- Gate	AISI304	AISI316
3- Packing gland	CF8M	CF8M
4- Support plates	STEEL	STEEL
5- Seal	EPDM	EPDM
6. Ring	AISI316	AISI316
7- Stem	AISI303	AISI303
8- Yoke	GJS-500	GJS-500
9- Handwheel	GJS-500	GJS-500
10- Stem nut	BRONZE	BRONZE
11- Stopper Nut	STEEL	STEEL
12- Packing seal.	EPDM	EPDM
13- Packing	SYNT + PTFE	SYNT + PTFE
14- Hood nut	5.6 ZINC	5.6 ZINC
15 Hood	STEEL	STEEL
16- Protection cap	PLASTIC	PLASTIC
17- Slides	RCH1000	RCH1000

table 1

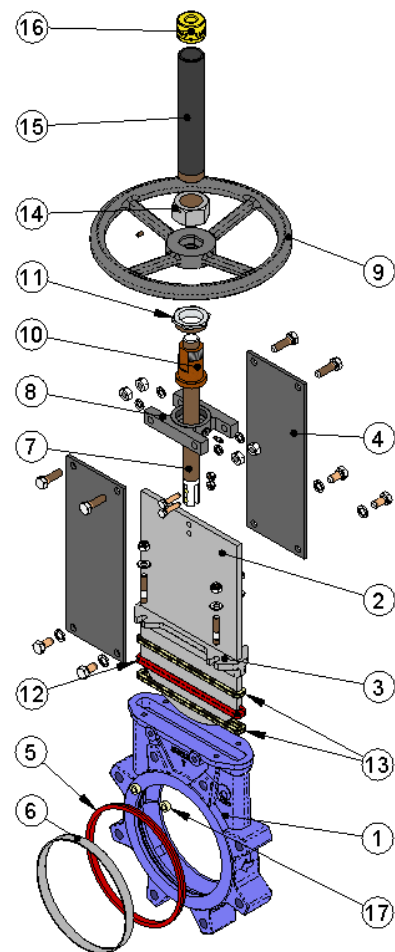

fig. 2

C.M.O.

Amategui Aldea 142, 20400 Txarama-Tolosa (SPAIN)

TEC-T.EN11

Tel. Nacional: 902.40.80.50 Fax: 902.40.80.51 / Tel. Internacional: 34.943.67.33.99 Fax: 34.943.67.24.40

cmo@cmo.es <http://www.cmo.es>

page 2

DESIGN CHARACTERISTICS

1- BODY

Monobloc "LUG" cast body with interior slides for optimum movement of the gate and wedges for improved seal tightness. Face-to-face dimension in accordance with MSS-SP-81 standard.

Designed with full passage to provide large flows with small losses of load.

The body's internal design prevents any build up of solids in the seat area.

The standard manufacturing materials are A216WCB carbon steel and CF8M stainless steel. Other materials and stainless steel alloys (AISI316Ti, Duplex, 254SMO, Uranus B6....) are available upon request. As standard, carbon steel valves are painted with an anti-corrosive protection of 80 microns of EPOXY (colour RAL 5015). Other types of anti-corrosive protections are available on request.

2- GATE

The standard manufacturing materials are AISI304 stainless steel in valves with carbon steel body and AISI316 stainless steel in valves with CF8M body. Other materials or combinations can be supplied on request.

The gate is polished on both sides to provide a smooth contact surface with the resilient seat. At the same time, the gate is rounded to prevent the seat from being cut. Different degrees of polishing, anti-abrasion treatments and modifications are available to adapt the valves to the customer's requirements.

3- SEAT: (seal-tight)

Six types of seats are available according to the working application:

-Seat 1: Metal / metal seat. This type of seat does not include any kind of resilient seat and the estimated leakage (considering water as the test fluid) is 1.5% of the pipe flow.

-Seat 2: Standard soft-seated valve. This type of seat includes a resilient seat which is fixed to the inside of the body via an AISI316 stainless steel retaining ring.

-Seat 3: Soft-seated valve with reinforced socket. This type of seat includes a resilient seat which is fixed to the inside of the body via a reinforced retaining ring with two functions (to protect the valve from abrasion and clean the gate when working with solids that can stick to it).

-Seats 4, 5 and 6: The same as seats 1, 2 and 3 but including a deflector. The deflector is an O-ring located at the valve input with two functions: firstly to protect the valve from abrasion and secondly to guide the flow to the centre of the valve.

***Note:** Three materials are available for the reinforced socket and the deflector: Steel CA-15, CF8M and Ni-hard.

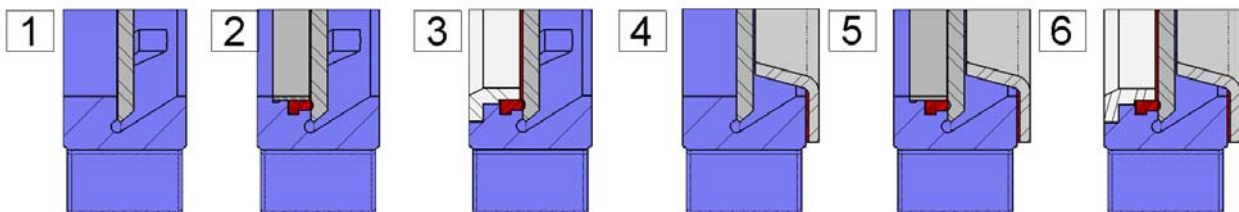

fig. 3

Resilient seat materials

EPDM

This is the standard resilient seat fitted on **C.M.O.** valves. It can be used in many applications, however, it is generally used for water and products diluted in water at temperatures no higher than 90°C*. It can also be used with abrasive products and it provides the valve with 100% watertight integrity.

NITRILE

It is used in fluids containing fats or oils at temperatures no higher than 90°C*. It provides the valve with 100% watertight integrity.

VITON

Suitable for corrosive applications and continuous high temperatures of up to 190°C and peaks of 210°C. It provides the valve with 100% watertight integrity.

SILICONE

Mainly used in the food industry and for pharmaceutical products with temperatures no higher than 200°C. It provides the valve with 100% watertight integrity.

PTFE

Suitable for corrosive applications and pH between 2 and 12. Does not provide the valve with 100% watertight integrity. Estimated leakage: 0.5% of the tube flow.

 **Note:** In some applications other types of resilient materials are used, such as hypalon, butile or natural rubber. Please contact us if you require one of these materials.

4- PACKING

C.M.O. standard packing is composed of three lines with a specially designed EPDM seal in the middle which provides seal-tightness between the body and the gate, preventing any type of leakage to the atmosphere. It is located in an easily accessible place and can be replaced without dismantling the valve from the pipeline. Below we indicate various types of packing available according to the application to be given to the valve:

GREASED COTTON (Recommended for hydraulic services)

This packing is composed of braided cotton fibres soaked in grease both inside and out. It is for general use in hydraulic applications in both pumps and valves.

DRY COTTON

This packing is composed of cotton fibres. It is for general use in hydraulic applications with solids.

COTTON + PTFE

This packing is composed of braided cotton fibres soaked in PTFE both inside and out. It is for general use in hydraulic applications in both pumps and valves.

SYNTHETIC + PTFE

This packing is composed of braided synthetic fibres soaked in PTFE both inside and out. It is for general use in hydraulic applications in both pumps and valves and in all types of fluids, especially corrosive ones, including concentrated and oxidising oils. It is also used in liquids with solid particles in suspension.

GUILLOTINE VALVES

T-TAPPI SERIES

LUBRICATED PTFE

It is made with PTFE filaments and designed to work at great speed. It is braided with a diagonal system. Suitable for valves and pumps which work with almost all types of fluids, particularly with the most corrosive, such as: oxidant and concentrated oils. It is also used in liquids with solid content.

GRAPHITE

This packing is composed of high-purity graphite fibres. A diagonal braiding system is used and it is impregnated with graphite and lubricant which helps to reduce porosity and improve operation.

It has a wide range of applications as graphite is resistant to steam, water, oils, solvents, alkali and most acids.

CERAMIC FIBRE

This packing is composed of ceramic material fibres. Its main applications are with air or gas at high temperatures and low pressures.

They are located in an easily accessible place and can be replaced without dismantling the valve from the pipeline.

SEAT/SEALS			PACKING			
Material	Max. T. (°C)	Applications	Material	P(bar)	Max. T. (°C)	pH
Metal/Metal	>250	High temp./Low watertight integ.	Greased cotton	10	100	6-8
EPDM (E)	90 *	Non-mineral oils, acids and water.	Dry cotton (AS)	0.5	100	6-8
Nitrile (N)	90 *	Hydrocarbons, oils and greases	Cotton + PTFE	30	120	6-8
Viton (V)	200	Hydrocarbons and solvents	Synthetic + PTFE	100	-200+270	0-14
Silicone (S)	200	Food Products	Graphite	40	650	0-14
PTFE (T)	250	Resistant to corrosion	Ceramic Fibre	0.3	1400	0-14

NOTE: More details and other materials available on request.

* → EPDM and nitrile: is possible until serving temperature Max.: 120°C under request.

table 2

5- STEM

The **C.M.O.** valve stem is made from stainless steel 18/8. This characteristic makes it highly resistant and provides excellent properties against corrosion.

The valve design can be rising stem or non-rising stem. When a rising stem is required for the valve, a stem hood is supplied to protect the stem from contact with dust and dirt, besides keeping it lubricated.

6- PACKING GLAND

The packing gland allows uniform force and pressure to be applied to the packing to ensure seal-tightness.

As standard, **C.M.O. T-TAPPI** serial valves have the CF8M gland.

7- ACTUATORS

All types of actuators can be supplied, with the advantage that thanks to the **C.M.O.** design they are fully interchangeable. This design allows the customer to change the actuators themselves and no extra assembly accessories are required. A design characteristic of **C.M.O.** valves is that all actuators are interchangeable.

Manual:

Handwheel with rising stem
 Handwheel with non-rising stem
 Chainwheel
 Lever
 Geared motor
 Others (square nut, etc)

Automatic:

Electric actuator
 Pneumatic cylinder
 Hydraulic cylinder

C.M.O.

Amategui Aldea 142, 20400 Txarama-Tolosa (SPAIN)

TEC-T.EN11

Tel. Nacional: 902.40.80.50 Fax: 902.40.80.51 / Tel. Internacional: 34.943.67.33.99 Fax: 34.943.67.24.40

cmo@cmo.es <http://www.cmo.es>

page 5

GUILLOTINE VALVES

T-TAPPI SERIES

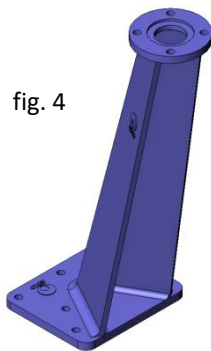

fig. 4

Wide range of accessories available:

Mechanical stops
 Locking devices
 Emergency manual actuators
 Electrovalves
 Positioners
 Limit switches
 Proximity switches
 Straight floor stands (fig. 5)
 Leaning floor stand (Fig. 4)
 ...

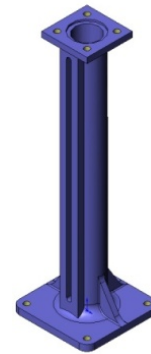

fig. 5

Stem extensions have also been developed, allowing the actuator to be located far away from the valve, to suit all needs. Please consult our technicians beforehand.

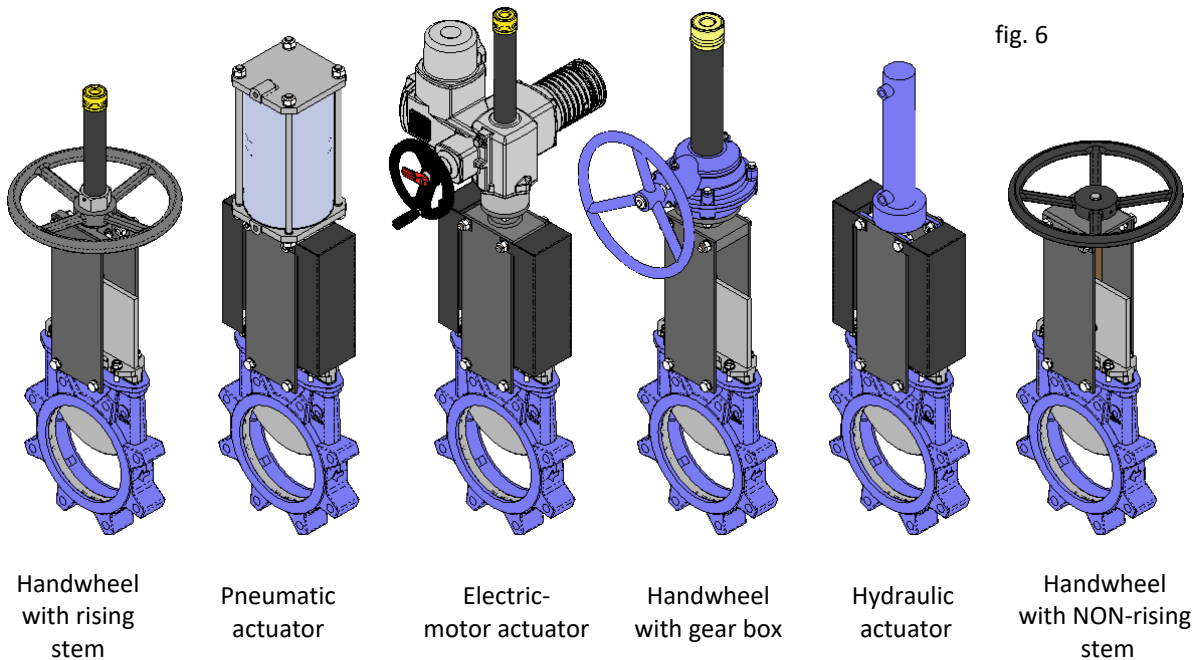

fig. 6

Handwheel with rising stem

Pneumatic actuator

Electric-motor actuator

Handwheel with gear box

Hydraulic actuator

Handwheel with NON-rising stem

ACCESSORIES AND OPTIONS

Different accessories are available to adapt the valve to specific working conditions such as:

- Mirror Polished Gate:

The mirror polished gate is especially recommended in the food industry and, as standard, in applications in which solids can stick to the gate. It is an alternative to ensure the solids slide off and do not stick to the gate.

- PTFE Lined Gate:

As with the mirror polished gate, it improves the valve's resistance to products that can stick to the gate.

- Stellite Gate:

Stellite is added to the gate's internal circle to protect it from abrasion.

GUILLOTINE VALVES

T-TAPPI SERIES

- Scraper in the packing:

Its function is to clean the gate during the opening movement and prevent possible damage to the packing.

- Air injections in the packing gland:

By injecting air in the packing, an air chamber is created which improves the seal-tightness.

- Heating Jacket:

Recommended in applications in which the fluid can harden and solidify inside the valve's body. An external jacket keeps the body temperature constant, preventing the fluid from solidifying.

- Flushing holes in body:

Several holes are drilled in the body to flush air, steam or other fluids out with the aim of cleaning the valve seat before sealing.

- Electrovalves (Fig. 7):

For air distribution to pneumatic actuators.

- Connection boxes, wiring and pneumatic piping:

Units supplied fully assembled with all the necessary accessories.

- Mechanical limit switches, inductive switches and positioners:

Limit switches or inductive switches are installed to indicate precise valve position, as well as positioners to indicate continuous position (Fig. 7).

- Mechanical Locking Device:

Allows the valve to be mechanically locked in a set position for long periods.

- Stroke limiting mechanical stops:

They allow the stroke to be mechanically adjusted, limiting the valve run

- Emergency Manual Actuator (Hand Wheel /Gear Box) (Fig. 7):

Allows manual operation of the valve in the event of power or air failure.

- Triangular (V-Notch) and Pentagonal Diaphragm with Indication Rule:

Recommended for application in which it is necessary to regulate the flow, it allows flow control according to the valve's opening percentage.

- Interchangeable actuators:

All actuators are easily interchangeable.

- Actuator or yoke support:

Made of EPOXY-coated steel (or stainless steel on request), its robust design gives it great rigidity in order to resist the most adverse operation conditions.

- Epoxy coating:

All carbon steel bodies and components of **C.M.O.** valves are EPOXY coated, giving the valves great resistance to corrosion and an excellent surface finish. **C.M.O.**'s standard colour is blue RAL-5015.

- Gate safety protection:

In accordance with European Safety Standards ("EC" marking), **C.M.O.** automated valves are equipped with gate guards, to prevent any objects from being accidentally caught or dragged in the gate.

- Bonnet:

Provides total seal-tightness to the outside, reducing the packing maintenance required.

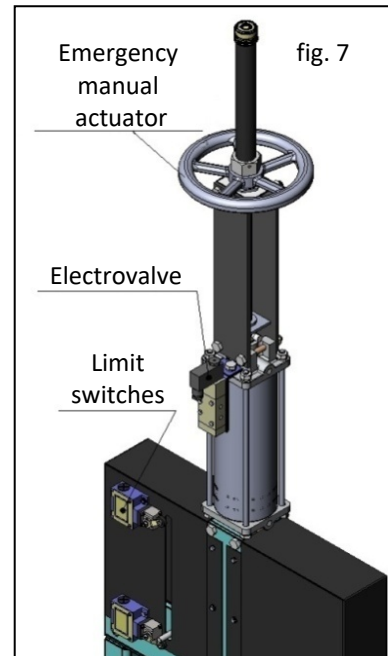

GUILLOTINE VALVES

T-TAPPI SERIES

TYPES OF EXTENSION

When the valve needs to be operated from a distance, the following different types of actuators can be fitted:

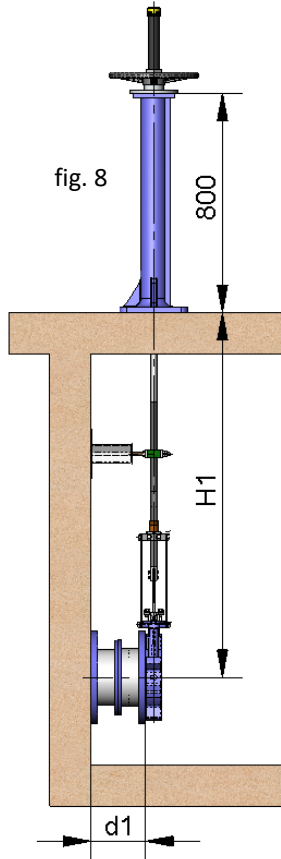

1 - Extension: Floor Stand.

This extension is performed by coupling a rod to the stem. By defining the length of the rod, the desired extension is achieved. A floor stand is normally installed to support the actuator.

The definition variables are as follows:

H1: Distance from the valve shaft to the base of the stand.

d1: Separation from the wall to the end of the connecting flange.

Characteristics:

- It can be coupled to any type of actuator.
- A stem support-guide is recommended (fig. 9) every 1.5 m.
- The standard floor stand is 800 mm high (fig. 8). Other floor stand measurements available on request.
- A position indicator can be fitted to determine the valve's percentage of opening.
- Possibility of leaning floor stand (fig. 10).

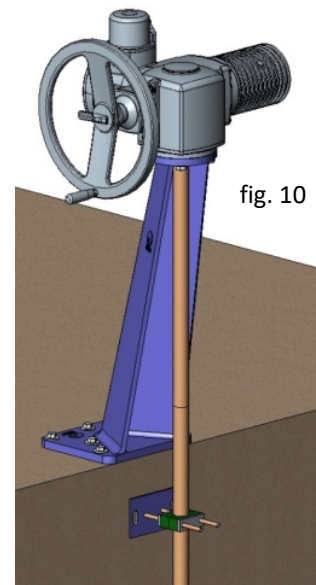
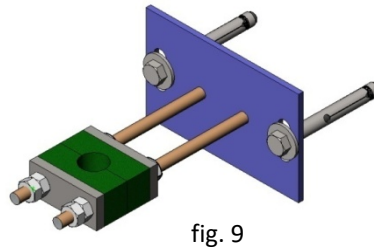

COMPONENTS LIST	
Component	Standard Version
Stem	AISI 303
Stem	AISI 304
Support-Guide	Carbon steel with EPOXI coating
Slide	Nylon
Floor Stand	GJS-500 with EPOXY coating

table 3

C.M.O.

Amategui Aldea 142, 20400 Txarama-Tolosa (SPAIN)

TEC-T.EN11

Tel. Nacional: 902.40.80.50 Fax: 902.40.80.51 / Tel. Internacional: 34.943.67.33.99 Fax: 34.943.67.24.40

cmo@cmo.es <http://www.cmo.es>

page 8



GUILLOTINE VALVES

T-TAPPI SERIES

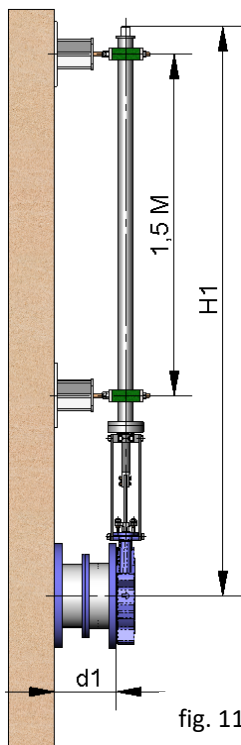

fig. 11

2 - Extension: Pipe (fig. 11)

Consists of raising the actuator. The pipe will rotate with the wheel or key when the valve is operated, although this will always remain at the same height.

The definition variables are as follows:

H1: Distance from the valve shaft to the desired height of the actuator.

d1: Separation from the wall to the end of the connecting flange.

Characteristics:

- Standard actuators: Handwheel and "Square Nut".
- A pipe support-guide is recommended every 1.5m.
- The standard materials are: EPOXY coated carbon steel or stainless steel.

3 - Extension: Extended Support Plates (Fig. 12)

When a short extension is required, it can be achieved by extending the support plates. An intermediate yoke can be fitted to reinforce the support plates' structure.

fig. 12

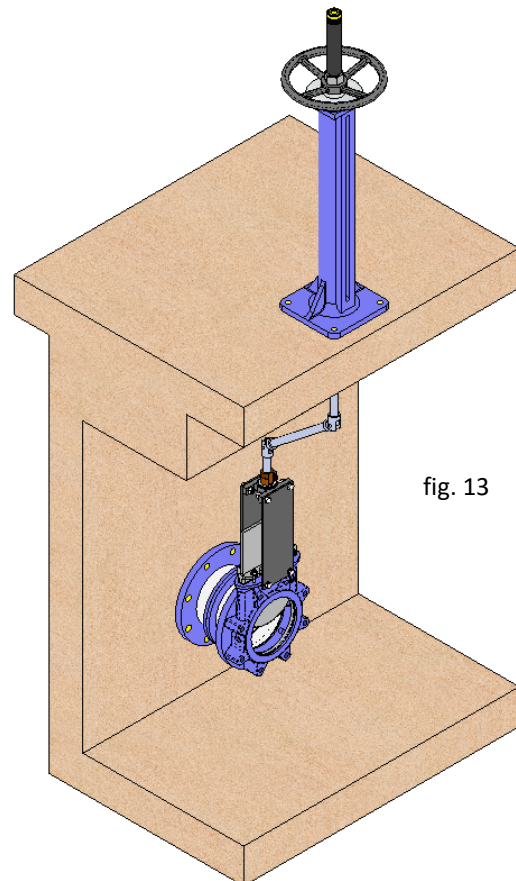
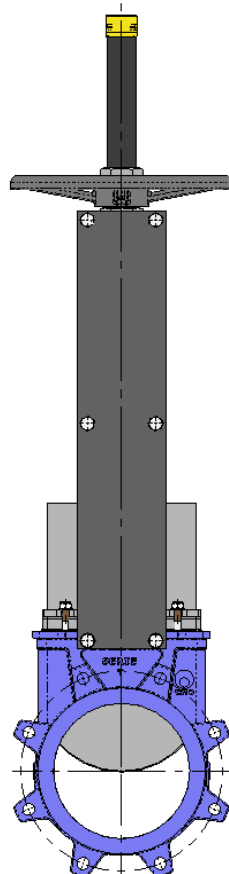

fig. 13

4 - Extension: Universal Joint (Fig. 13)

If the valve and the actuator are not in correct alignment, the problem can be resolved by fitting a universal joint.

GUILLOTINE VALVES

T-TAPPI SERIES

HANDWHEEL with rising stem

- **B = Max.** width of the valve (without actuator).
- **D = Max.** height of the valve (without actuator).
- Options:
 - Locking devices.
 - Extensions: stand, pipe, plates, etc.
 - DN higher than those shown in the table.
- Actuator including:
 - Handwheel.
 - Stem.
 - Nut.
 - Stem protection hood.
- Available: ND50 - 2" to ND1200 - 48", other ND on request.
- From ND350 - 14" the actuator is with geared motor.

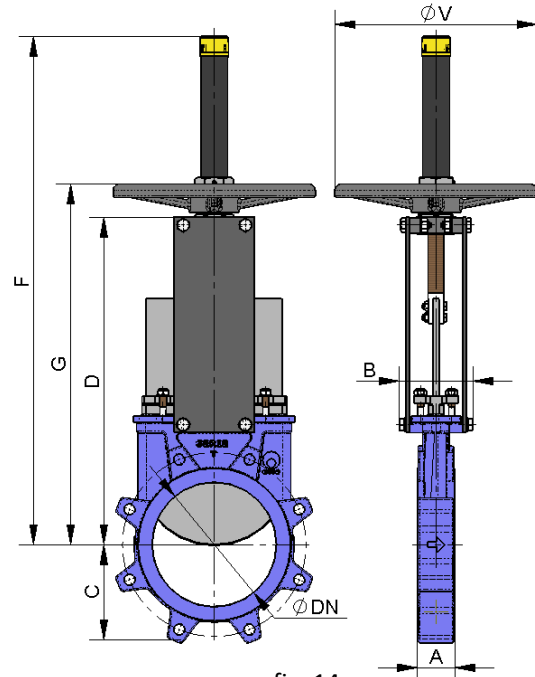

fig. 14

DN	ND	ΔP (Kg/cm ²)	DRAW (Nw)	TORQUE (Nm)	A		B	C	D	G	F	ØV
					(mm)	(")						
50	2"	10	829	2	47.6	1 7/8"	91	61	241	280	410	225
65	2 1/2"	10	1399	3	47.6	1 7/8"	91	68	268	308	437	225
80	3"	10	2119	5	50.8	2"	91	91	294	333	463	225
100	4"	10	3310	8	50.8	2"	91	104	334	373	503	225
125	5"	10	5171	12	57.2	2 1/4"	101	118	367	407	586	225
150	6"	10	7448	17	57.2	2 1/4"	101	130	419	458	638	225
200	8"	10	13251	38	69.9	2 3/4"	118	159	525	578	816	325
250	10"	10	20722	59	69.9	2 3/4"	118	196	626	679	1017	325
300	12"	10	29871	85	76.2	3"	118	231	726	779	1117	380
350	14"	10	40719	158	76.2	3"	290	257	797	906	1337	450
400	16"	10	53304	207	88.9	3 1/2"	290	290	903	--	--	--
450	18"	10	67470	262	88.9	3 1/2"	290	312	989	--	--	--
500	20"	10	83305	371	114.3	4 1/2"	290	340	1101	--	--	--
600	24"	10	120265	658	114.3	4 1/2"	290	398	1307	--	--	--
700	28"	8	131344	718	114.3	4 1/2"	320	453	1506	--	--	--
750	30"	8	151204	827	117.5	4 5/8"	320	489	1620	--	--	--
800	32"	8	172093	1116	117.5	4 5/8"	320	503	1720	--	--	--
900	36"	8	218402	1417	117.5	4 5/8"	320	583	1953	--	--	--
1000	40"	4	136102	883	117.5	4 5/8"	320	613	2137	--	--	--
1100	44"	4	165592	1074	152.4	6"	340	670	2375	--	--	--
1200	48"	4	197039	1278	152.4	6"	340	728	2616	--	--	--

table 4

C.M.O.

Amategui Aldea 142, 20400 Txarama-Tolosa (SPAIN)

TEC-T.EN11

Tel. Nacional: 902.40.80.50 Fax: 902.40.80.51 / Tel. Internacional: 34.943.67.33.99 Fax: 34.943.67.24.40

cmo@cmo.es <http://www.cmo.es>

page 10

GUILLOTINE VALVES

T-TAPPI SERIES

HANDWHEEL with non-rising stem

- Suitable when no size limitations exist.
- **B = Max.** width of the valve (without actuator).
D = Max. height of the valve (without actuator).
- Options:
 - Square nut.
 - Locking devices.
 - Extensions: stand, pipe, plates,...
 - DN higher than those shown in the table.
- Actuator including:
 - Handwheel.
 - Stem.
 - Guide bushing on the yoke.
 - Nut.
- Available: ND50 - 2" to ND1200 - 48", other ND on request.
- From ND350 - 14" the actuator is with geared motor.

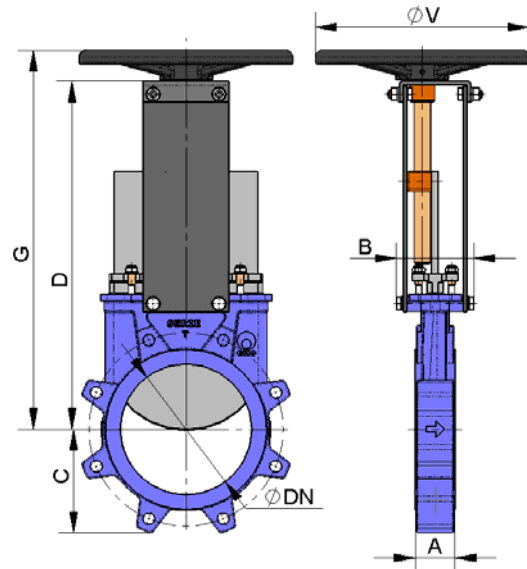

fig. 15

DN	ND	ΔP (Kg/cm ²)	DRAW (Nw)	TORQUE (Nm)	A		B	C	D	G	ØV
					(mm)	(")					
50	2"	10	829	2	47.6	1 7/8"	91	61	241	280	225
65	2 1/2"	10	1399	3	47.6	1 7/8"	91	68	268	308	225
80	3"	10	2119	5	50.8	2"	91	91	294	333	225
100	4"	10	3310	8	50.8	2"	91	104	334	373	225
125	5"	10	5171	12	57.2	2 1/4"	101	118	367	407	225
150	6"	10	7448	17	57.2	2 1/4"	101	130	419	458	225
200	8"	10	13251	38	69.9	2 3/4"	118	159	525	578	325
250	10"	10	20722	59	69.9	2 3/4"	118	196	626	679	325
300	12"	10	29871	85	76.2	3"	118	231	726	779	380
350	14"	10	40719	158	76.2	3"	290	257	797	906	450
400	16"	10	53304	207	88.9	3 1/2"	290	290	903	--	--
450	18"	10	67470	262	88.9	3 1/2"	290	312	989	--	--
500	20"	10	83305	371	114.3	4 1/2"	290	340	1101	--	--
600	24"	10	120265	658	114.3	4 1/2"	290	398	1307	--	--
700	28"	8	131344	718	114.3	4 1/2"	320	453	1506	--	--
750	30"	8	151204	827	117.5	4 5/8"	320	489	1620	--	--
800	32"	8	172093	1116	117.5	4 5/8"	320	503	1720	--	--
900	36"	8	218402	1417	117.5	4 5/8"	320	583	1953	--	--
1000	40"	4	136102	883	117.5	4 5/8"	320	613	2137	--	--
1100	44"	4	165592	1074	152.4	6"	340	670	2375	--	--
1200	48"	4	197039	1278	152.4	6"	340	728	2616	--	--

table 5

C.M.O.

Amategui Aldea 142, 20400 Txarama-Tolosa (SPAIN)

TEC-T.EN11

Tel. Nacional: 902.40.80.50 Fax: 902.40.80.51 / Tel. Internacional: 34.943.67.33.99 Fax: 34.943.67.24.40

cmo@cmo.es <http://www.cmo.es>

page 11

GUILLOTINE VALVES

T-TAPPI SERIES

CHAINWHEEL

- Widely used in raised installations with difficult access, the handwheel is fitted in vertical position.
- **B = Max.** width of the valve (without actuator).
D = Max. height of the valve (without actuator).
- Options:
 - Locking devices.
 - Extensions: stand, pipe, plates,...
 - Non-rising stem.
 - DN higher than those shown in the table.
- Including:
 - Handwheel.
 - Stem.
 - Nut.
 - Hood.
- Available: ND50 - 2" to ND1200 - 48", other ND on request.
- From ND350 - 14" the actuator is with geared motor, see * in table.

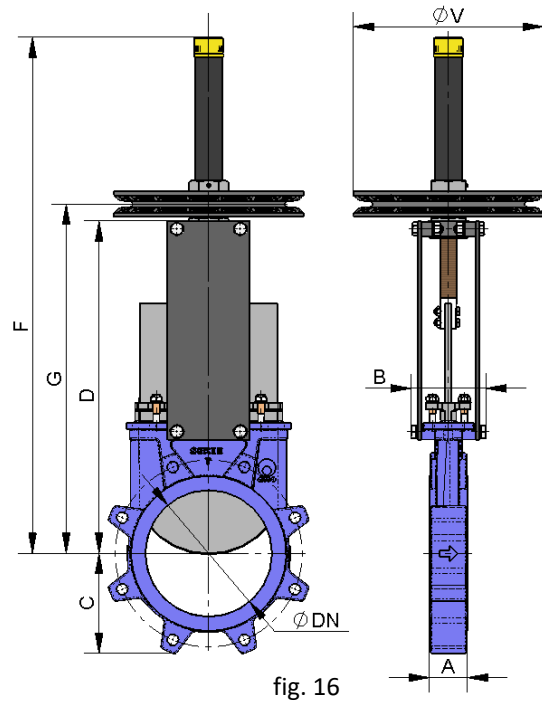

fig. 16

DN	ND	ΔP (Kg/cm ²)	DRAW (Nw)	TORQUE (Nm)	A		B	C	D	G	F	ØV
					(mm)	(")						
50	2"	10	829	2	47.6	1 7/8"	91	61	241	280	410	225
65	2 1/2"	10	1399	3	47.6	1 7/8"	91	68	268	308	437	225
80	3"	10	2119	5	50.8	2"	91	91	294	333	463	225
100	4"	10	3310	8	50.8	2"	91	104	334	373	503	225
125	5"	10	5171	12	57.2	2 1/4"	101	118	367	407	586	225
150	6"	10	7448	17	57.2	2 1/4"	101	130	419	458	638	225
200	8"	10	13251	38	69.9	2 3/4"	118	159	525	578	816	300
250	10"	10	20722	59	69.9	2 3/4"	118	196	626	679	1017	300
300	12"	10	29871	85	76.2	3"	118	231	726	779	1117	300
350	14"	10	40719	158	76.2	3"	290	257	797	906	1337	402
400	16"	10	53304	207*	88.9	3 1/2"	290	290	903	997	1441	402*
450	18"	10	67470	262*	88.9	3 1/2"	290	312	989	1083	1677	402*
500	20"	10	83305	371*	114.3	4 1/2"	290	340	1101	1195	1789	402*
600	24"	10	120265	658*	114.3	4 1/2"	290	398	1307	1420	2108	402*
700	28"	8	131344	718*	114.3	4 1/2"	320	453	1506	1658	2406	402*
750	30"	8	151204	827*	117.5	4 5/8"	320	489	1620	1775	2565	402*
800	32"	8	172093	1116*	117.5	4 5/8"	320	503	1720	1905	2790	402*
900	36"	8	218402	1417*	117.5	4 5/8"	320	583	1953	2115	3130	402*
1000	40"	4	136102	883*	117.5	4 5/8"	320	613	2137	2310	3440	402*
1100	44"	4	165592	1074*	152.4	6"	340	670	2375	2565	3765	402*
1200	48"	4	197039	1278*	152.4	6"	340	728	2616	2815	4050	402*

table 6

C.M.O.

Amategui Aldea 142, 20400 Txarama-Tolosa (SPAIN)

TEC-T.EN11

Tel. Nacional: 902.40.80.50 Fax: 902.40.80.51 / Tel. Internacional: 34.943.67.33.99 Fax: 34.943.67.24.40

cmo@cmo.es <http://www.cmo.es>

GUILLOTINE VALVES

T-TAPPI SERIES

LEVER

- It is a fast actuator.
- **B = Max. width** of the valve (without actuator).
- **D = Max. height** of the valve (without actuator).
- The actuator includes:
 - Lever.
 - Stem.
 - Guide bushing.
 - External locking devices to maintain the position.
- Available: ND50 - 2" to ND200 - 8", other ND on request.

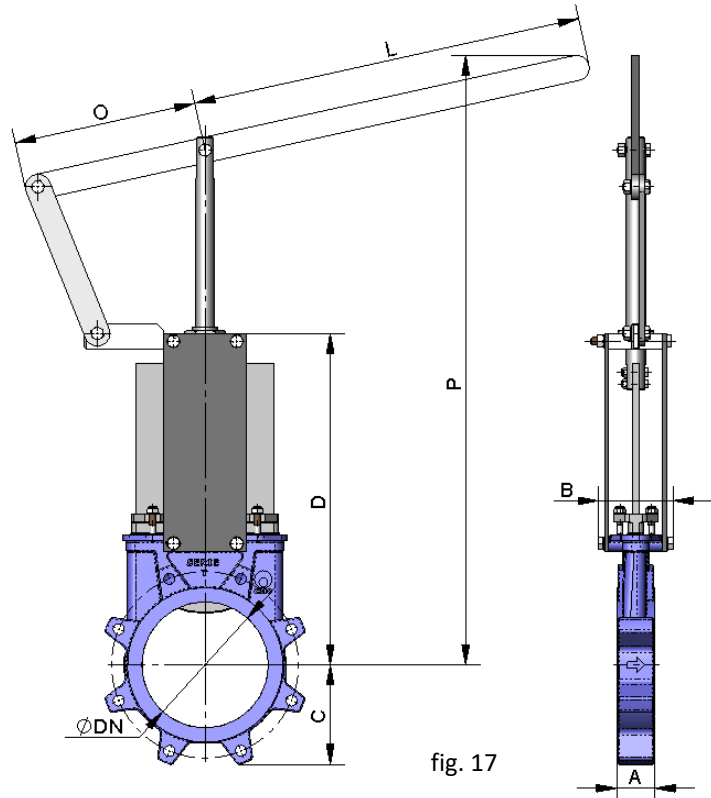

DN	ND	ΔP (Kg/cm ²)	DRAW (Nw)	A		B	C	D	L	O	P
				(mm)	(")						
50	2"	10	829	47.6	1 7/8"	91	61	241	325	155	504
65	2 1/2"	10	1399	47.6	1 7/8"	91	68	268	325	155	526
80	3"	10	2119	50.8	2"	91	91	294	325	155	549
100	4"	10	3310	50.8	2"	91	104	334	325	155	605
125	5"	10	5171	57.2	2 1/4"	101	118	367	425	155	902
150	6"	10	7448	57.2	2 1/4"	101	130	419	425	155	956
200	8"	10	13251	69.9	2 3/4"	118	159	525	620	290	1027

table 7

GUILLOTINE VALVES

T-TAPPI SERIES

GEAR BOX

- It is recommendable for ND greater than 350 - 14".
- **B = Max.** width of the valve (without actuator).
D = Max. height of the valve (without actuator).
- Options:
 - Chainwheel.
 - Locking devices.
 - Extensions: stand, pipe, plates,...
 - Non-rising stem.
- Actuator including:
 - Stem.
 - Yoke.
 - Cone-shaped gear box.
 - Handwheel.
- Standard reduction ratio = 4 to 1.
- Available: ND 50 - 2" to ND 1200 - 48", other ND on request.

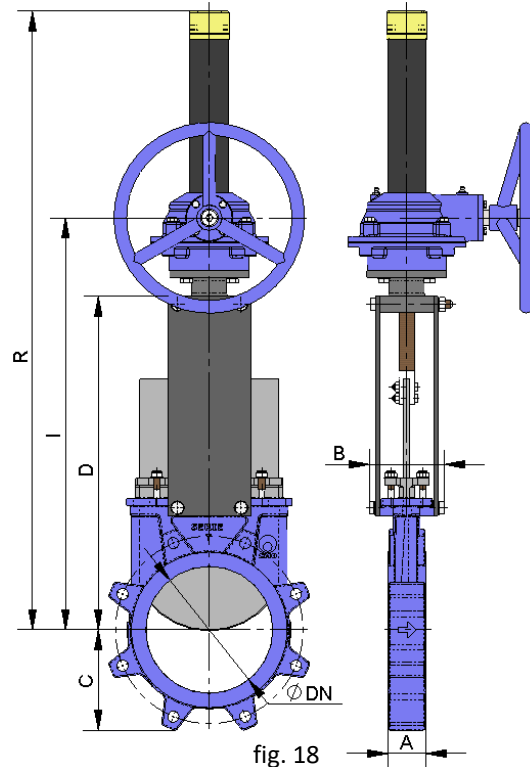

DN	ND	ΔP (Kg/cm ²)	DRAW (Nw)	TORQUE (Nm)	A		B	C	D	I	R
					(mm)	(")					
50	2"	10	829	2	47.6	1 7/8"	91	61	241	366	540
65	2 1/2"	10	1399	3	47.6	1 7/8"	91	68	268	392	566
80	3"	10	2119	5	50.8	2"	91	91	294	418	592
100	4"	10	3310	8	50.8	2"	91	104	334	458	632
125	5"	10	5171	12	57.2	2 1/4"	101	118	367	491	665
150	6"	10	7448	17	57.2	2 1/4"	101	130	419	543	717
200	8"	10	13251	38	69.9	2 3/4"	118	159	525	648	942
250	10"	10	20722	59	69.9	2 3/4"	118	196	626	749	1043
300	12"	10	29871	85	76.2	3"	118	231	726	849	1193
350	14"	10	40719	158	76.2	3"	290	257	797	891	1335
400	16"	10	53304	207	88.9	3 1/2"	290	290	903	997	1441
450	18"	10	67470	262	88.9	3 1/2"	290	312	989	1083	1677
500	20"	10	83305	371	114.3	4 1/2"	290	340	1101	1195	1789
600	24"	10	120265	658	114.3	4 1/2"	290	398	1307	1420	2108
700	28"	8	131344	718	114.3	4 1/2"	320	453	1506	1658	2406
750	30"	8	151204	827	117.5	4 5/8"	320	489	1620	1775	2565
800	32"	8	172093	1116	117.5	4 5/8"	320	503	1720	1905	2790
900	36"	8	218402	1417	117.5	4 5/8"	320	583	1953	2115	3130
1000	40"	4	136102	883	117.5	4 5/8"	320	613	2137	2310	3440
1100	44"	4	165592	1074	152.4	6"	340	670	2375	2565	3765
1200	48"	4	197039	1278	152.4	6"	340	728	2616	2815	4050

table 8

C.M.O.

Amategui Aldea 142, 20400 Txarama-Tolosa (SPAIN)

TEC-T.EN11

Tel. Nacional: 902.40.80.50 Fax: 902.40.80.51 / Tel. Internacional: 34.943.67.33.99 Fax: 34.943.67.24.40

cmo@cmo.es <http://www.cmo.es>

page 14

GUILLOTINE VALVES

T-TAPPI SERIES

DOUBLE-ACTING PNEUMATIC CYLINDER

- The air supply pressure to the pneumatic cylinder is a minimum of 6 Kg/cm² and a maximum of 10 Kg/cm², the air must be dry and lubricated.
 - 10 Kg/cm² is the maximum admissible air pressure. For air pressures below 6 Kg/cm², please consult to **C.M.O.**
 - For ND50 - 2" to ND200 - 8" valves, the cylinder's jacket and covers are made of aluminium, the rod of AISI304, the piston of rubber-coated steel and the O-ring seals are made of nitrile.
 - For valves larger than ND200 - 8" the covers are made of nodular cast iron or carbon steel.
- On request, we can also supply the actuator made entirely of stainless steel, especially for installation in corrosive atmospheres.
- **B = Max.** width of the valve (without actuator).
 - **D = Max.** height of the valve (without actuator).
- Available: ND50 - 2" to ND750 - 30", other ND on request.

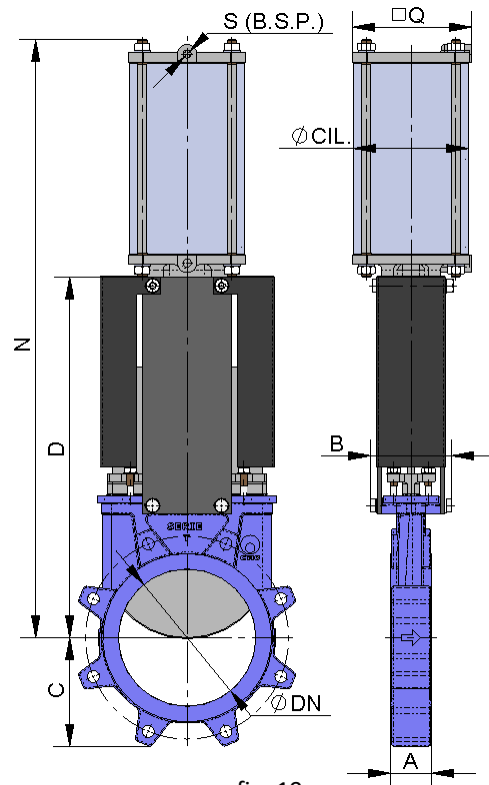

fig. 19

DN	ND	ΔP (Kg/cm ²)	DRAW (Nw)	A		B	C	D	N	Q	Ø CYL.	Ø STEM	S (B.S.P.)
				(mm)	(")								
50	2"	10	829	47.6	1 7/8"	91	61	241	416	90	80	20	1/4"
65	2 1/2"	10	1399	47.6	1 7/8"	91	68	268	456	90	80	20	1/4"
80	3"	10	2119	50.8	2"	91	91	294	498	90	80	20	1/4"
100	4"	10	3310	50.8	2"	91	104	334	562	110	100	20	1/4"
125	5"	10	5171	57.2	2 1/4"	101	118	367	636	135	125	25	1/4"
150	6"	10	7448	57.2	2 1/4"	101	130	419	723	170	160	30	1/4"
200	8"	10	13251	69.9	2 3/4"	118	159	525	886	215	200	30	3/8"
250	10"	10	20722	69.9	2 3/4"	118	196	626	1133	270	250	40	3/8"
300	12"	10	29871	76.2	3"	118	231	726	1278	382	300	45	1/2"
350	14"	10	40719	76.2	3"	290	257	797	1383	444	350	45	1/2"
400	16"	10	53304	88.9	3 1/2"	290	290	903	1532	508	400	50	1/2"
450	18"	*	*	88.9	3 1/2"	290	312	989	*	*	*	*	*
500	20"	*	*	114.3	4 1/2"	290	340	1101	*	*	*	*	*
600	24"	*	*	114.3	4 1/2"	290	398	1307	*	*	*	*	*
700	28"	*	*	114.3	4 1/2"	320	453	1506	*	*	*	*	*
750	30"	*	*	117.5	4 5/8"	320	489	1620	*	*	*	*	*

* → Consult

table 9

C.M.O.

Amategui Aldea 142, 20400 Txarama-Tolosa (SPAIN)

TEC-T.EN11

Tel. Nacional: 902.40.80.50 Fax: 902.40.80.51 / Tel. Internacional: 34.943.67.33.99 Fax: 34.943.67.24.40

cmo@cmo.es <http://www.cmo.es>

page 15



GUILLOTINE VALVES

T-TAPPI SERIES

SINGLE-ACTING PNEUMATIC CYLINDER

- The air supply pressure to the pneumatic cylinder is a minimum of 6 Kg/cm² and a maximum of 10 Kg/cm², the air must be dry and lubricated.
- 10 Kg/cm² is the maximum admissible air pressure. For air pressures below 6 Kg/cm², please consult to **C.M.O.**
- Available for opening or closing in case of air supply failure (spring opening or closing).
- The jacket is made of aluminium, the covers of nodular cast iron or carbon steel, the rod of AISI304, the piston of rubber-coated steel, the O-ring seals of nitrile and the spring is made of steel.
- The **actuator design is spring activated** for valves with diameters **up to ND200 - 8"**. For larger diameters the actuator contains a double-acting cylinder and an air tank which stores the volume of air necessary to perform the last movement in the event of an air supply failure.
- **B = Max.** width of the valve (without actuator).
D = Max. height of the valve (without actuator).
- Available: ND50 - 2" to ND200 - 8", other ND on request.

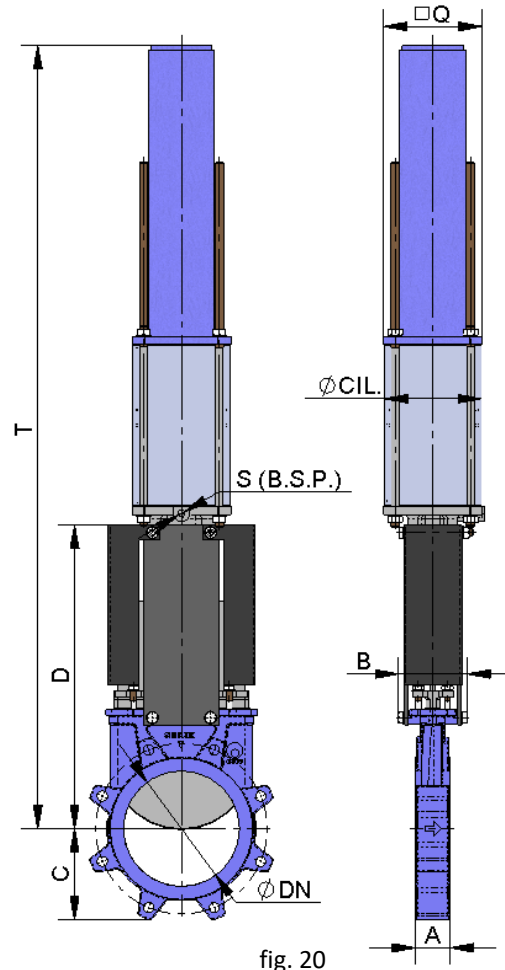

fig. 20

DN	ND	ΔP (Kg/cm ²)	DRAW (Nw)	A		B	C	D	Q	T	Ø CYL.	Ø STEM	S (B.S.P.)
				(mm)	(")								
50	2"	10	829	47.6	1 7/8"	91	61	241	135	781	125	25	1/4"
65	2 1/2"	10	1399	47.6	1 7/8"	91	68	268	135	806	125	25	1/4"
80	3"	10	2119	50.8	2"	91	91	294	135	833	125	25	1/4"
100	4"	10	3310	50.8	2"	91	104	334	135	873	125	25	1/4"
125	5"	10	5171	57.2	2 1/4"	101	118	367	170	910	160	30	1/4"
150	6"	10	7448	57.2	2 1/4"	101	130	419	215	1265	200	30	3/8"
200	8"	10	13251	69.9	2 3/4"	118	159	525	270	1800	250	40	3/8"

table 10

GUILLOTINE VALVES

T-TAPPI SERIES

ELECTRIC ACTUATOR

- This actuator is automatic and includes the following parts:
 - Electric motor.
 - Stem.
 - Yoke.
- The electric motor includes:
 - Emergency manual handwheel.
 - Limit switches.
 - Torque limiters.
- Options:
 - Different types and brands.
 - Non-rising stem.
- ISO 5210 / DIN 3338 Flanges.
- Available: ND50 - 2" to ND1200 - 48", other ND on request.
- From ND300 - 12" the motor is assisted with a gear box.

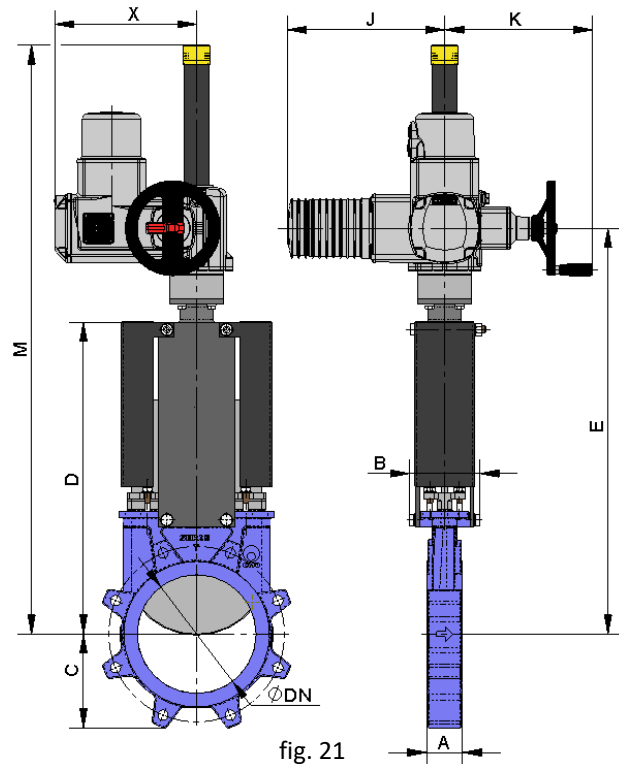

fig. 21

DN	ND	ΔP (Kg/cm ²)	DRAW (Nw)	TORQUE (Nm)	A		B	C	D	E	J	K	M	X
					(mm)	(")								
50	2"	10	829	2	47.6	1 7/8"	91	61	241	400	265	250	581	238
65	2 1/2"	10	1399	3	47.6	1 7/8"	91	68	268	426	265	250	607	238
80	3"	10	2119	5	50.8	2"	91	91	294	452	265	250	632	238
100	4"	10	3310	8	50.8	2"	91	104	334	492	265	250	672	238
125	5"	10	5171	12	57.2	2 1/4"	101	118	367	525	265	250	705	238
150	6"	10	7448	17	57.2	2 1/4"	101	130	419	577	265	250	757	238
200	8"	10	13251	38	69.9	2 3/4"	118	159	525	683	265	250	988	238
250	10"	10	20722	59	69.9	2 3/4"	118	196	626	774	265	250	1089	238
300	12"	10	29871	85	76.2	3"	118	231	726	874	283	255	1189	248
350	14"	10	40719	158	76.2	3"	290	257	797	931	265	250	1335	422
400	16"	10	53304	207	88.9	3 1/2"	290	290	903	1037	265	250	1441	422
450	18"	10	67470	262	88.9	3 1/2"	290	312	989	1123	265	250	1677	422
500	20"	10	83305	371	114.3	4 1/2"	290	340	1101	1245	283	255	1789	424
600	24"	10	120265	658	114.3	4 1/2"	290	398	1307	1470	283	255	2108	479
700	28"	8	131344	718	114.3	4 1/2"	320	453	1506	1708	283	255	2406	479
750	30"	8	151204	827	117.5	4 5/8"	320	489	1620	1825	283	255	2565	479
800	32"	8	172093	1116	117.5	4 5/8"	320	503	1720	1955	283	255	2790	605
900	36"	8	218402	1417	117.5	4 5/8"	320	583	1953	2165	283	255	3130	605
1000	40"	4	136102	883	117.5	4 5/8"	320	613	2137	2377	389	335	3440	479
1100	44"	4	165592	1074	152.4	6"	340	670	2375	2642	389	335	3765	605
1200	48"	4	197039	1278	152.4	6"	340	728	2616	2882	389	335	4050	605

table 11

C.M.O.

Amategui Aldea 142, 20400 Txarama-Tolosa (SPAIN)

TEC-T.EN11

Tel. Nacional: 902.40.80.50 Fax: 902.40.80.51 / Tel. Internacional: 34.943.67.33.99 Fax: 34.943.67.24.40

cmo@cmo.es <http://www.cmo.es>

page 17



GUILLOTINE VALVES

T-TAPPI SERIES

HYDRAULIC ACTUATOR (Oil pressure: 135 Kg/cm²)

- **B = Max. width of the valve (without actuator).**
D = Max. height of the valve (without actuator).
- The hydraulic actuator includes:
 - Hydraulic cylinder.
 - Yoke.
- Available: ND50 - 2" to ND1200 - 48".
- Different types and brands available according to customer's requirements.

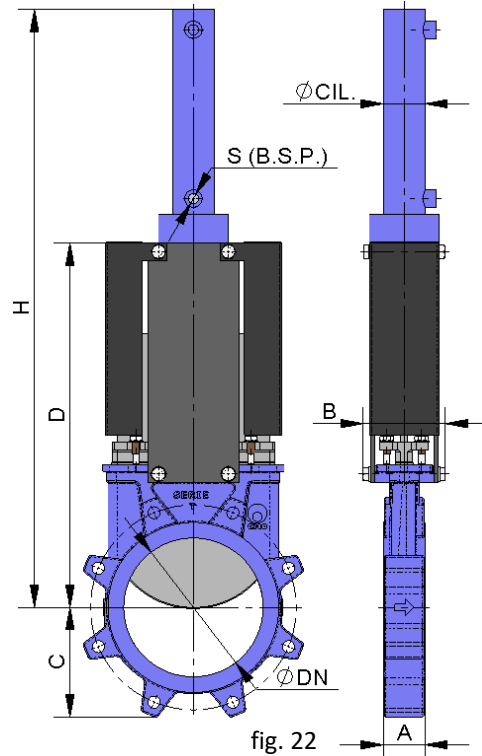

DN	ND	ΔP (Kg/cm ²)	DRAW (Nw)	A		B	C	D	H	Ø CYL.	Ø STEM	S (B.S.P.)	Oil cap. (dm ³)
				(mm)	(")								
50	2"	10	829	47.6	1 7/8"	91	61	241	457	25	18	3/8"	0.03
65	2 1/2"	10	1399	47.6	1 7/8"	91	68	268	500	25	18	3/8"	0.04
80	3"	10	2119	50.8	2"	91	91	294	560	25	18	3/8"	0.04
100	4"	10	3310	50.8	2"	91	104	334	620	32	22	3/8"	0.09
125	5"	10	5171	57.2	2 1/4"	101	118	367	683	32	22	3/8"	0.11
150	6"	10	7448	57.2	2 1/4"	101	130	419	755	40	28	3/8"	0.2
200	8"	10	13251	69.9	2 3/4"	118	159	525	926	50	28	3/8"	0.42
250	10"	10	20722	69.9	2 3/4"	118	196	626	1077	63	36	3/8"	0.81
300	12"	10	29871	76.2	3"	118	231	726	1246	80	45	3/8"	1.56
350	14"	10	40719	76.2	3"	290	257	797	1376	100	56	1/2"	2.87
400	16"	10	53304	88.9	3 1/2"	290	290	903	1532	100	56	1/2"	3.26
450	18"	10	67470	88.9	3 1/2"	290	312	989	1707	125	70	1/2"	5.71
500	20"	10	83305	114.3	4 1/2"	290	340	1101	1869	125	70	1/2"	6.32
600	24"	10	120265	114.3	4 1/2"	290	398	1307	2202	160	70	1/2"	12.37
700	28"	8	131344	114.3	4 1/2"	320	453	1506	2525	160	70	1/2"	14.38
750	30"	8	151204	117.5	4 5/8"	320	489	1620	2670	160	70	1/2"	15.38
800	32"	8	172093	117.5	4 5/8"	320	503	1720	2818	160	70	1/2"	16.39
900	36"	8	218402	117.5	4 5/8"	320	583	1953	3193	200	90	1/2"	28.75
1000	40"	4	136102	117.5	4 5/8"	320	613	2137	3437	160	70	1/2"	20.41
1100	44"	4	165592	152.4	6"	340	670	2375	3775	160	70	1/2"	22.42
1200	48"	4	197039	152.4	6"	340	728	2616	4161	200	90	1/2"	38.17

table 12

C.M.O.

Amategui Aldea 142, 20400 Txarama-Tolosa (SPAIN)

TEC-T.EN11

Tel. Nacional: 902.40.80.50 Fax: 902.40.80.51 / Tel. Internacional: 34.943.67.33.99 Fax: 34.943.67.24.40

cmo@cmo.es <http://www.cmo.es>

page 18

GUILLOTINE VALVES

T-TAPPI SERIES

INFORMATION ON FLANGE DIMENSIONS

EN 1092-2 PN10

DN	ÄP (Kg/cm ²)	Qty. ●	Qty. ○	Metric	P	ØK
50	10	2	2	M 16	8	125
65	10	2	2	M 16	8	145
80	10	2	6	M 16	9	160
100	10	2	6	M 16	9	180
125	10	2	6	M 16	9	210
150	10	2	6	M 20	10	240
200	10	2	6	M 20	10	295
250	10	4	8	M 20	12	350
300	10	4	8	M 20	12	400
350	10	6	10	M 20	14	460
400	10	6	10	M 24	21	515
450	10	8	12	M 24	22	565
500	10	8	12	M 24	22	620
600	10	8	12	M 27	22	725
700	8	10	14	M 27	22	840
750	8	10	14	M 30	22	900
800	8	10	14	M 30	22	950
900	8	12	16	M 30	20	1050
1000	4	12	16	M 33	20	1160
1100	4	14	18	M 33	20	1270
1200	4	14	18	M 36	22	1380

table 13

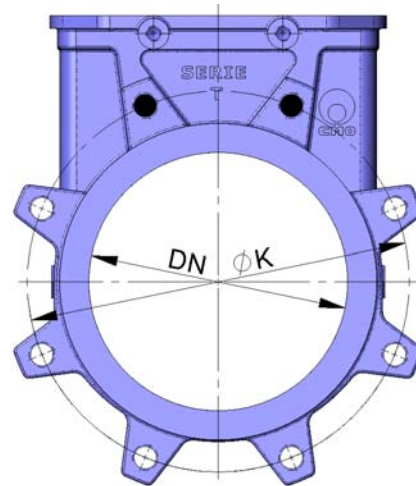

fig. 23

- BLIND TAPPED HOLE
- THROUGH TAPPED HOLE

ANSI B16, class 150

ND	ÄP (psi)	Qty. ●	Qty. ○	R UNC	P	ØK
2"	150	2	2	5/8"	8	120,6
2 ½"	150	2	2	5/8"	8	139,7
3"	150	2	2	5/8"	9	152,4
4"	150	2	6	5/8"	9	190,5
5"	150	2	6	3/4"	9	215,9
6"	150	2	6	3/4"	10	241,3
8"	150	2	6	3/4"	10	298,4
10"	150	4	8	7/8"	12	361,9
12"	150	4	8	7/8"	12	431,8
14"	150	4	8	1"	14	476,2
16"	150	6	10	1"	21	539,7
18"	150	6	10	1 ⅛"	22	577,8
20"	150	8	12	1 ⅛"	22	635
24"	150	8	12	1 ¼"	22	749,3
28"	125	12	16	1 ¼"	22	863,6
30"	125	12	16	1 ¼"	22	914,4
32"	125	12	16	1 ½"	22	977,9
36"	125	14	18	1 ½"	20	1085,9
40"	50	14	22	1 ½"	20	1200,2
44"	50	16	24	1 ½"	20	1314,4
48"	50	18	26	1 ½"	22	1422,4

table 14

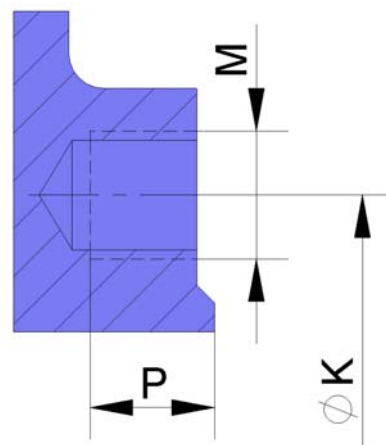

fig. 24

C.M.O.

Amategui Aldea 142, 20400 Txarama-Tolosa (SPAIN)

TEC-T.EN11

Tel. Nacional: 902.40.80.50 Fax: 902.40.80.51 / Tel. Internacional: 34.943.67.33.99 Fax: 34.943.67.24.40

cmo@cmo.es <http://www.cmo.es>

page 19