



CMO VALVES

manufacturing the valve you need

11A SERIES



FABRICATION RANGE METAL SEAT GATE VALVE

UTILIZATION:

- Metal seat gate valve for pumping, irrigation, drinking water supply, treatment and pumping of dirty water, etc.
- It has minimum head loss, and full bore.

11 - SERIES

METAL SEAT GATE VALVES



GENERAL FEATURES:

- Minimum head loss.
- Full bore.
- Bidirectional flow.
- RF type DIN PN 10/16 flanges.
- Guided gate to ensure the correct sealing.
- WRAS certificate for drinking water.
- Max. working pressure according to design pressure PN10/16.
- Working temperature between -10°C and 90°C.

STANDARDS APPLIED:

- EC Directive.
- Distance between flanges according to EN 558 series 14/15.
- Side flanges according to ISO 7005-2.

DIMENSIONS

DN	L (F4)	L (F5)	H
40	140	240	214
50	150	250	232
65	170	270	258
80	180	280	281
100	190	300	315
125	200	325	358
150	210	350	408
200	230	400	500
250	250	450	572
300	270	500	662
350	290	550	751
400	310	600	832

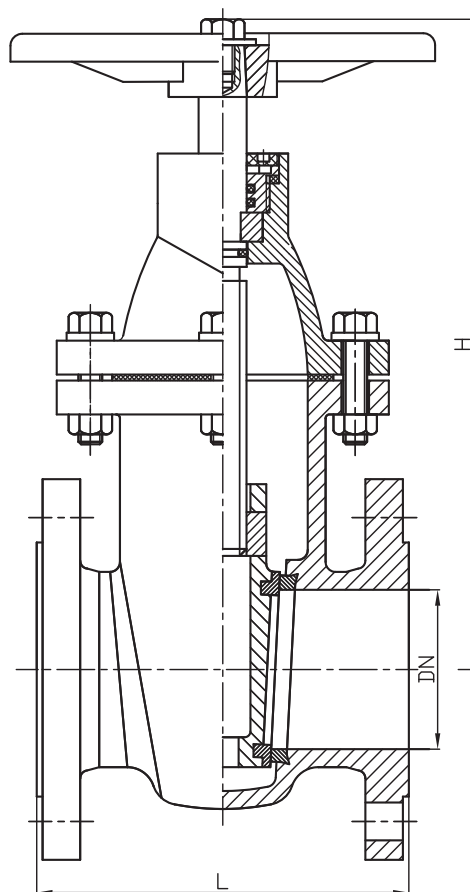

The images and drawings are non contractual.
The specifications of the shown products could vary without previous notice.

11 - SERIES

METAL SEAT GATE VALVES



DESCRIPTION		
1	BODY	GJS500
2	BODY SEAT RING	BRASS
3	WEDGE	GJS500
4	WEDGE SEAT RING	BRASS
5	STEM NUT	BRASS
6	STEM	AISI 420
7	GASKET	NBR
8	BONNET	GJS500
9	O-RING	NBR
10	LOCATING RING	BRASS
11	O-RING	NBR
12	BONNET NUT	BRASS
13	MINIPAD	PTFE
14	DUST RING	NBR
15	HANDWHEEL	GJS500
	BOLTS, NUTS, WASHERS	A2
	PAINTING RAL 5015	Epoxy 250 μ m

