



CONSTRUCCIONES  
METÁLICAS  
DE OBTURACIÓN, S.L.

**CMO**



GESTION DE  
LA CALIDAD  
CERTIFICADA

QUALITY  
MANAGEMENT  
CERTIFIED

**KNIFE-GATE VALVES**

**F SERIES**

18/04/2016

# INSTRUCTIONS AND MAINTENANCE MANUAL

## SERIES: F

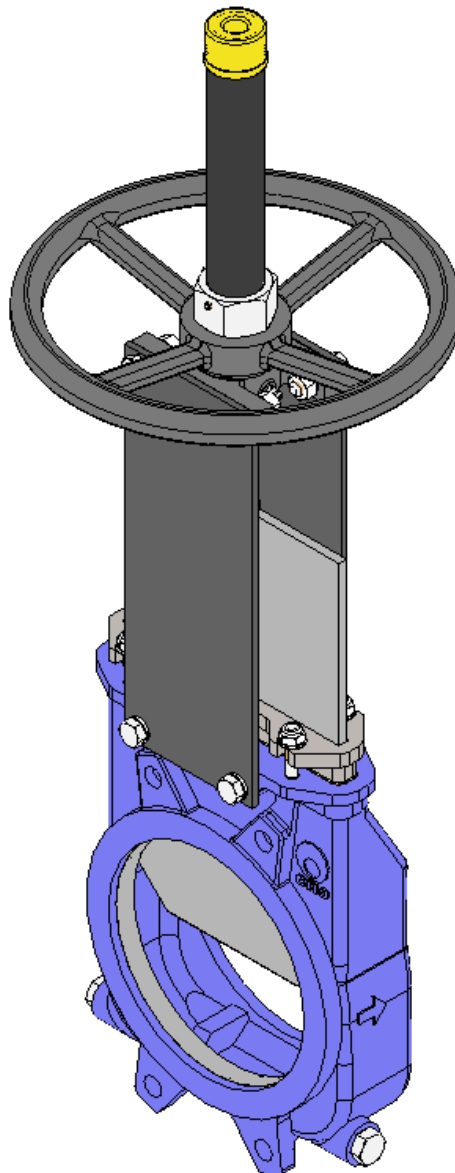

C.M.O.

Amategui Aldea 142, 20400 Txarama-Tolosa (SPAIN)

MAN-F.EN04

Tel. National: 902.40.80.50 Fax: 902.40.80.51 / Tel. International: 34.943.67.33.99 Fax: 34.943.67.24.40

[cmo@cmo.es](mailto:cmo@cmo.es) <http://www.cmo.es>

Page 1

## ASSEMBLY

### THE F VALVE COMPLIES WITH THE FOLLOWING:

Machinery Directive: **DIR 2006/42/EC (MACHINERY)**

Pressure Equipment Directive: **DIR 97/23/EC (PED) ART.3, P.3**

Potential Explosive Atmospheres Directive (optional): **DIR 94/9/CE (ATEX) CAT.3 ZONE 2 and 22 GD.**

Valve **F** complies with the Directive on Equipment and Protective Systems for Potentially Explosive Atmospheres. In these cases the logo will appear on the identification label. This label shows the exact classification of the zone in which the valve can be used. The user is responsible for its use in any other zone.



### HANDLING

When handling the equipment please pay special attention to the following points:

- **SAFETY WARNING:** Before handling the valve check that the crane to be used is capable of bearing its weight.
- To prevent damage, especially to the anticorrosive protection, it is recommended to use soft straps to lift the **C.M.O.** knife gate valves. These straps must be fitted around the top of body.
- Do not lift the valve or hold it by the actuator. Lifting the valve by the actuator can lead to operating problems as it is not designed to withstand the valve's weight.
- Do not lift the valve by holding it in the flow passage area. The valve's O-ring seal is located in this area. If the valve is held and lifted by this area it can damage the surface and the O-ring seal and lead to leakage problems whilst the valve is operating.
- Packing in wooden boxes: If the equipment is packed in wooden boxes these must be provided with clearly marked holding areas where the slings will be placed when securing them. In the event that two or more valves are packed together, separation and securing elements must be provided between them to prevent possible movements, knocks and friction during transport. When storing two or more valves in the same box you must ensure they are correctly supported to prevent deformations. In the case of dispatches by sea we recommend the use of vacuum bags inside the boxes to protect the equipment from contact with sea water.
- Pay special attention to maintaining the correct levelling of the valves during loading and unloading as well as during transport to prevent deformations in the equipment. For this purpose we recommend the use of mounts or trestles.



### INSTALLATION

In order to avoid personal harm and other type of damage (to the facilities, the valve, etc.) please follow these instructions:

- The staff responsible for the installation or operation of the equipment must be qualified and trained.
- Use suitable Personal Protective Equipment (PPE) (gloves, safety boots, goggles...).
- Shut off all lines that affect the valve and put up a warning sign to inform about the work being performed.
- Completely isolate the valve from the whole process. Depressurise the process.
- Drain all the line's fluid through the valve.
- Use hand tools not electric tools during the installation and maintenance, in accordance with **EN13463-1(15)**.



# KNIFE-GATE VALVES

# F SERIES

Before installation, inspect the valve to ensure no damage has occurred during transport or storage.

Make sure that the inside of the valve's body and, in particular, the seal area are clean. Inspect the installation's pipes and the flanges to make sure they are clean.

The F valve is unidirectional and an arrow is marked on the body indicating the flow direction.

The word SEAT is also marked on one side of the body (near the packing gland) to indicate the side where the sealing joint is located.

The valve's normal working position is indicated in Fig. 1.

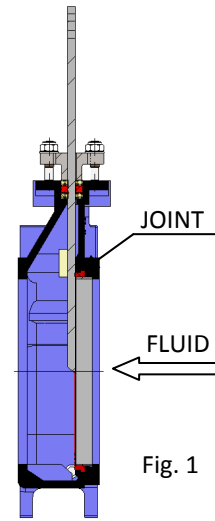

### ASPECTS TO BE CONSIDERED DURING ASSEMBLY

- Special care must be taken to respect the correct distance (gap) between the flanges and ensure they are correctly aligned and parallel (Fig. 2).

The incorrect position or installation of the flanges can cause deformations on the valve's body and this could lead to operating problems.

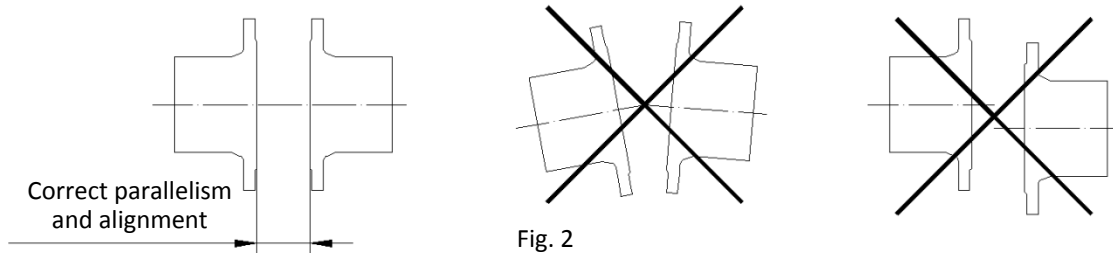

It is very important to make sure that the valve is correctly aligned and parallel to the flanges to prevent leakages and avoid deformations. Ensure the valve is assembled in open position.

- The screws in the tapped blind holes will have a maximum depth (Fig. 3) and will never reach the bottom of the hole. The following table (Table 1) shows the maximum thread depth in the holes and the maximum torque to be applied to the flange screws:

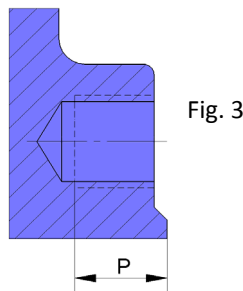

Table 1

<b>DN</b>	50	65	80	100	125	150	200	250	300	350	400	450	500	600	700	800	900	1000	1200
<b>P</b>	8	8	10	10	10	12	10	12	12	21	21	21	21	20	25	22	21	21	30
<b>TORQUE (Nm)</b>	45	45	45	45	45	88	88	88	88	88	152	152	152	223	223	303	303	412	529

C.M.O.

Amategui Aldea 142, 20400 Txarama-Tolosa (SPAIN)

MAN-F.EN04

Tel. National: 902.40.80.50 Fax: 902.40.80.51 / Tel. International: 34.943.67.33.99 Fax: 34.943.67.24.40

cmo@cmo.es <http://www.cmo.es>

Page 3

## KNIFE-GATE VALVES

## F SERIES

- The equipment must be firmly installed in the pipe. It will be joined to the pipe with a screw joint.
- The screws and nuts to be fitted must also be suitable for the operating conditions and their measurements must in accordance with the approved plans. The screws and nuts must be fitted diametrically.

To torque to apply to the fastening screws and nuts must be correct according to the applicable standard, we recommend the initial assembly be carried out with a low tightening torque and after all the screws are in place, the final torque is applied.

- As regards scaffolding, ladders and other auxiliary elements to be used during the assembly, follow the safety recommendations indicated in this dossier.
- Once the equipment has been assembled make sure that there are no elements, whether interior or exterior, which can interfere with the gate valve's movement.
- Make the relevant connections (electrical, pneumatic, hydraulic) in the equipment's drive system following the instructions and wiring diagrams supplied it.
- The operation of the equipment must be coordinated with the site's control and safety staff and no modifications are permitted in the equipment's external indication elements (limit switches, positioners, etc.).
- When operating the equipment follow the safety recommendations indicated in this dossier.

### ASSEMBLY POSITIONS

This valve is mainly designed for bin outlets, which is why it is usually assembled in the horizontal position, as shown in the following diagram (fig. 4).

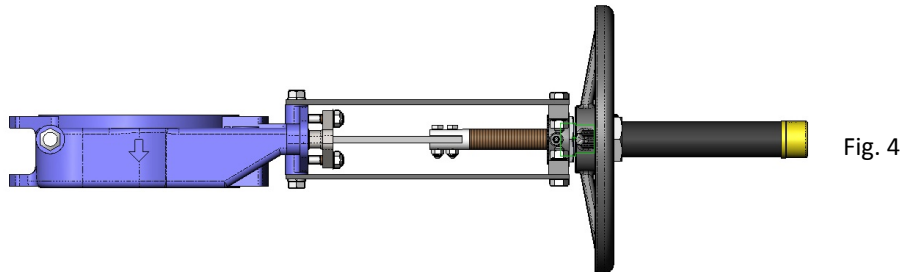

It is generally assembled under the hopper. This assembly position and the shape of the inside of the body ensure that no solids accumulate inside, and allows the product to flow easily through the valve. It can also be assembled vertically in the horizontal pipe, in both cases it is recommended to assemble them with the joints between the flanges, to ensure watertight integrity between the flanges and the valve.

To install valves larger than ND200 in any of these positions please contact C.M.O.. In all these positions it is recommended to secure the actuator to prevent the shaft from bending due to the weight of the actuator. If this is not taken into account, it can lead to problems during the valve's operation. Once the valve has been installed, check that all the screws and nuts have been correctly tightened and that the whole valve action system has been correctly adjusted (electrical connections, pneumatic connections, instruments...).

All **C.M.O.** valves are tested at its facilities, however, during the handling and transport the screws on the packing gland can come loose and must be re-tightened.

Once the valve is installed in the pipeline and it has been pressurised, it is very important to check for any leakages from the packing gland to the atmosphere.

In the event of a leakage, tighten the screws on the packing gland crosswise until the leakage stops, ensuring that there is no contact between the packing gland and the gate.

C.M.O.

Amategui Aldea 142, 20400 Txarama-Tolosa (SPAIN)

MAN-F.EN04

Tel. National: 902.40.80.50 Fax: 902.40.80.51 / Tel. International: 34.943.67.33.99 Fax: 34.943.67.24.40

cmo@cmo.es <http://www.cmo.es>

Page 4

## KNIFE - GATE VALVES

## F SERIES

A very high tightening torque on the packing gland's screws can lead to problems, such as an increase in the torque required to drive the valve, reduction in the packing's working life, or the breaking of the packing gland. The correct tightening torques are indicated in Table 2:

Tightening torques for packing gland screws	
DN50 to DN125	25 Nm
DN150 to DN300	30 Nm
DN350 to DN1200	35 Nm

Table 2

Once the valve is installed in its place, check that the flanges and electrical and pneumatic connections are secure. If the valve has electrical accessories or you are in an ATEX zone, earth connections must be made before operating it.



If you are in an ATEX zone, check the continuity between the valve and the pipeline (EN 12266-2, annex B, points B.2.2.2. and B.2.3.1.). Check the pipeline's earth connection and the conductivity between the outlet and inlet pipelines.

## ACTUATOR

### HANDWHEEL (Rising or Non-Rising Stem and Stem with Gear Box)

To operate the valve: Turn the handwheel clockwise to close or anticlockwise to open.

### CHAINWHEEL

To operate the valve pull one of the chain's vertical drops, taking into account that locking is carried out when the chainwheel turns clockwise.

### LEVER

First loosen the position locking clamp located on the yoke. Once it is unlocked raise the lever to open or lower it to close. To complete the operation lock the lever again.

### PNEUMATIC (Double and Single Acting)

**C.M.O.** pneumatic actuators are designed to be connected to a 6 kg/cm<sup>2</sup> pneumatic network, although these cylinders support up to 10 kg/cm<sup>2</sup>.

The pressurised air used for the pneumatic actuator must be correctly filtered and lubricated.

This type of actuator does not require any adjustment, due to the fact that the pneumatic cylinder is designed for the exact stroke required by the valve.

### HYDRAULIC (Double and Single Acting)

**C.M.O.** hydraulic actuators are designed to work at a standard pressure of 135 kg/cm<sup>2</sup>.

This type of actuator does not require any adjustment, due to the fact that the hydraulic cylinder is designed for the exact stroke required by the valve.

### MOTORISED (Rising or Non-Rising Stem)

If the valve incorporates a motorised actuator it will be accompanied with the electric actuator supplier's instructions.

## KNIFE-GATE VALVES

## F SERIES

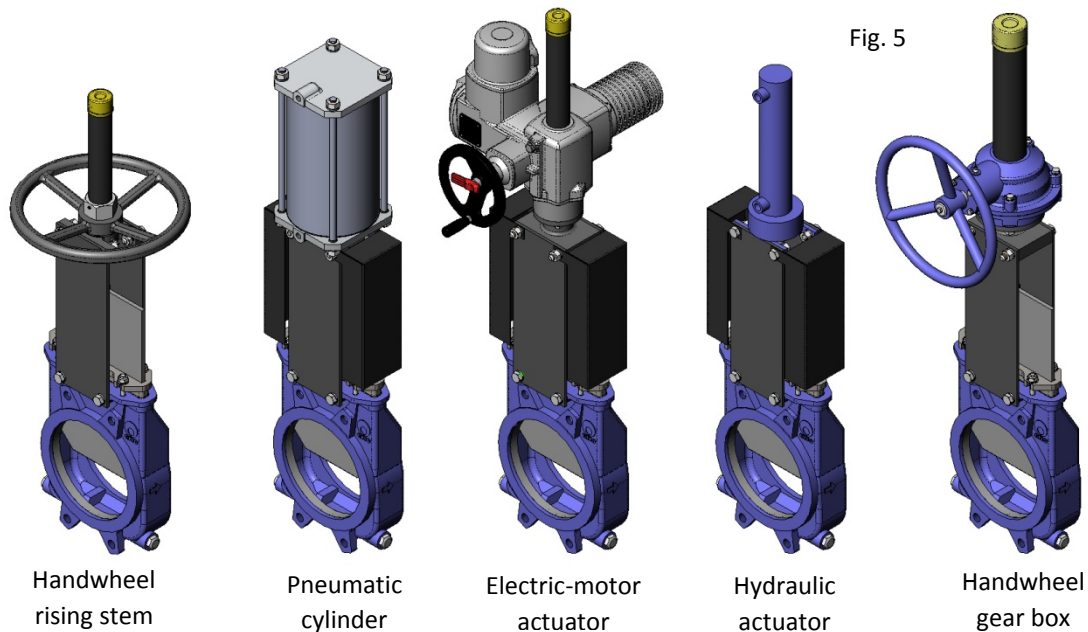

## MAINTENANCE

If the valves suffer any damage due to improper handling or without the proper authorisation, **C.M.O.** will not be responsible. The valves must not be modified except under express authorisation from **C.M.O.**

In order to avoid personal or material damage when performing the maintenance tasks, it is recommended to follow these instructions:

- The staff responsible for the maintenance or operation of the equipment must be qualified and trained.
- Use suitable Personal Protective Equipment (PPE) (gloves, safety boots, goggles...).
- Shut off all lines that affect the valve and put up a warning sign to inform about the work being performed.
- Completely isolate the valve from the whole process. Depressurise the process.
- Drain all the line's fluid through the valve.
- Use hand tools not electric tools during the maintenance, in accordance with **EN13463-1(15)**.



The only maintenance required in this type of valve is to change the seat's rubber joint (if soft seated valve is used) and the packing. It is recommended to regularly check the seal every 6 months, however its working life will depend on the valve's operating conditions, such as: Pressure, temperature, number of operations, type of fluid and others.



In an ATEX zone, electrostatic charges may be present inside the valve, which can cause a risk of explosion. The user will be responsible for carrying out the appropriate actions in order to minimise the risks.

- The maintenance staff must be informed about the risks of explosion and ATEX training is recommended.



-If the fluid transported constitutes an internal explosive atmosphere, the user must regularly check the installation's correct watertight integrity.

- Regularly clean the valve to prevent accumulation of dust.
- Assemblies not permitted at the end of the line.
- Avoid re-painting the products supplied.

C.M.O.

Amategui Aldea 142, 20400 Txarama-Tolosa (SPAIN)

MAN-F.EN04

Tel. National: 902.40.80.50 Fax: 902.40.80.51 / Tel. International: 34.943.67.33.99 Fax: 34.943.67.24.40

cmo@cmo.es <http://www.cmo.es>

Page 6



## KNIFE-GATE VALVES

## F SERIES

### IMPORTANT SAFETY ASPECTS:

- In order to work under ideal safety conditions, the magnetic and electrical elements must be in idle mode and the air tanks depressurised. The electrical control cabinets must also be out of service. The maintenance staff must be up to date with the safety regulations and work can only start under orders from the site's safety staff.
- The safety areas must be clearly marked and you must avoid placing auxiliary equipment (ladders, scaffolding, etc.) on levers or mobile parts which will lead to the movement of the gate valve.
- In equipment with spring return actuators, the gate must be mechanically locked and only unlocked when the actuator is pressurised.
- In equipment with electrical actuator, it is recommended to disconnect it from the mains in order to access the mobile parts without any risk.
- Due to its great importance, you must check that the valve's axle has no load before disassembling the actuator system.

Taking into account the recommendations indicated, below we indicate the maintenance operations carried out in this type of equipment:

### REPLACING THE SEALING JOINT (Watertight Valves)

1. Make sure there is absolutely no pressure and fluid in the installation.
2. Remove the valve from the pipeline.
3. Remove the actuator and safety guards (if present) by unscrewing and removing the bolts connecting the stem to the gate and the support plate to the body.
4. Remove the packing gland (3).
5. Remove the old packing (12 and 13) taking care not to damage its rubber strip.
6. Remove the gate (2) carefully without loosing the nylon slides (17).
7. Clean the inside surfaces of the valve.
8. Remove the ring (6) that secures the sealing joint (5). For this purpose, apply a few sharp knocks to the outside with a bronze object at the base of the ring until it comes out.
9. Remove the old sealing joint (5) and clean its housing.
10. Fit a new sealing joint (5) with the same dimensions as the old one or use the dimensions given in Table 3).
11. Insert the retaining ring (6) in its original position as indicated:
  - Place the retaining ring (6) in perfect alignment parallel to the sealing joint.
  - Push the ring (6) as a whole towards the base of the channel.
  - Check that all areas of the ring (6) are correctly inserted, in perfect contact with the valve and the joint (5) has not been damaged in the process.
12. The valve assembly will be performed in exactly the opposite way to the disassembly.

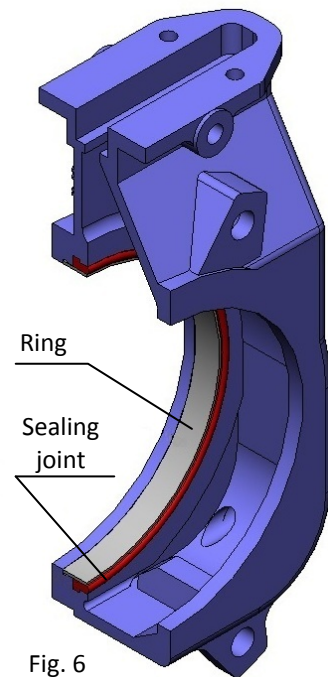

Fig. 6

 **Note:** The numbers in brackets refer to the components list in Table 7.

DN	50	65	80	100	125	150	200	250	300	350	400	450	500	600	700	800	900	1000	1200
Length (mm)	190	250	290	370	445	530	690	845	1005	1175	1350	1520	1710	2020	2300	2680	3030	3367	3995

Table 3

C.M.O.

Amategui Aldea 142, 20400 Txarama-Tolosa (SPAIN)

MAN-F.EN04

Tel. National: 902.40.80.50 Fax: 902.40.80.51 / Tel. International: 34.943.67.33.99 Fax: 34.943.67.24.40

cmo@cmo.es <http://www.cmo.es>

Page 7

## KNIFE-GATE VALVES

## F SERIES

 **Note:** During the assembly of the new sealing joint it is recommended to apply “Vaseline” to the seal to facilitate the assembly process and the valve’s correct operation (do not use oil or grease), below in Table 4 we show details of the Vaseline used by **C.M.O.**:

WHITE PETROLEUM JELLY		
Saybolt Colour	ASTM D-156	15
Meeting Point (°C)	ASTM D-127	60
Viscosity at 100°C	ASTM D-445	5
Penetration 25°C mm./10	ASTM D-937	165
Silicone Content	None	
Pharmacopeia BP	OK	

Table 4

### REPLACING THE SEALING JOINT (Teflon or PTFE)

You must follow the same operations that we have just described for the watertight valves, but the following aspects must also be taken into account:

- To obtain greater watertight integrity in the stainless steel bodies it is advisable to apply plastic glue to the joint housing. When the body is made of iron it is usually painted so this is not necessary.
- With the seal tab (5) pointing outwards, make a circle and then form a heart shape.
- It is recommendable to insert the joint in the top part, press the arched part and insert the seal into the housing.

### REPLACING THE PACKING

1. Make sure there is absolutely no pressure and fluid in the installation.
2. Place the valve in open position.
3. If the valve has safety protections, remove them.
4. Loosen the screws that connect the stem or rod to the gate.
5. Release the connection between the support plates and the body.
6. Loosen and remove the packing gland (3).
7. Remove the old packing (12 and 13) using a pointed tool, taking care not to damage the surface of the gate (2).
8. Carefully clean the packing and make sure there are no residues anywhere so that the new packing strips fit correctly.
9. Insert the new packing (12 and 13). During this operation it is very important for both ends to be perfectly joined. Below we show the packing dimensions (Table 5).

As standard, **C.M.O.** valve packing is composed of 3 lines (2 packing lines and 1 rubber joint line in the middle).

10. Place the packing gland in its original position (step 5), making sure it does not touch the gate, carefully tighten all the screws crosswise and make sure the same distance is left between the gate and the packing gland on both sides.
11. Screw down the support plates and the stem, in the reverse order to what is described in steps 4 and 5.
12. Perform several manoeuvres with no load, checking the correct operation of the valve and ensuring the packing gland is correctly centred.

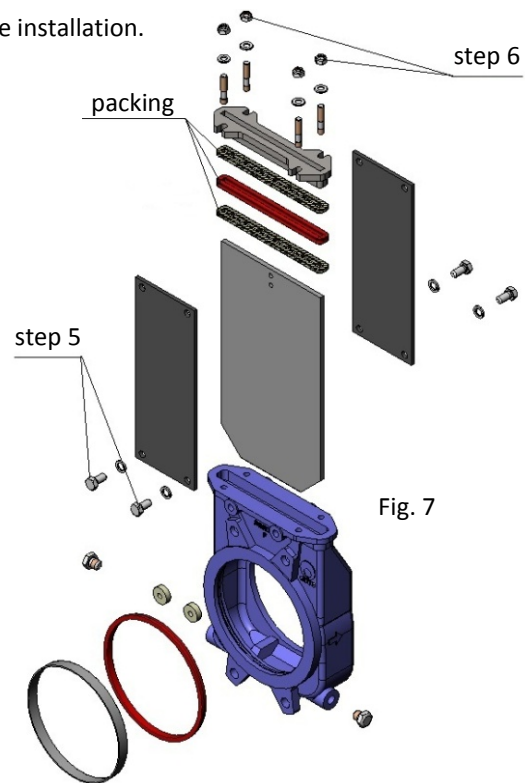



Fig. 7



## KNIFE-GATE VALVES

## F SERIES

13. Pressurise the valve in the line and tighten the packing gland crosswise, enough to prevent leakages to the atmosphere.

 **Note:** The numbers in brackets refer to the components list in Table 7.

DIAMETER	PACKING	RUBBER RING
DN50	2 lines of 8 mm <sup>2</sup> x 204 mm.	1 line of 8 mm <sup>2</sup> x 204 mm.
DN65	2 lines of 8 mm <sup>2</sup> x 234 mm.	1 line of 8 mm <sup>2</sup> x 234 mm.
DN80	2 lines of 8 mm <sup>2</sup> x 264 mm.	1 line of 8 mm <sup>2</sup> x 264 mm.
DN100	2 lines of 8 mm <sup>2</sup> x 304 mm.	1 line of 8 mm <sup>2</sup> x 304 mm.
DN125	2 lines of 8 mm <sup>2</sup> x 356 mm.	1 line of 8 mm <sup>2</sup> x 356 mm.
DN150	2 lines of 8 mm <sup>2</sup> x 406 mm.	1 line of 8 mm <sup>2</sup> x 406 mm.
DN200	2 lines of 8 mm <sup>2</sup> x 516 mm.	1 line of 8 mm <sup>2</sup> x 516 mm.
DN250	2 lines of 10 mm <sup>2</sup> x 636 mm.	1 line of 10 mm <sup>2</sup> x 636 mm.
DN300	2 lines of 10 mm <sup>2</sup> x 740 mm.	1 line of 10 mm <sup>2</sup> x 740 mm.
DN350	2 lines of 10 mm <sup>2</sup> x 810 mm.	1 line of 10 mm <sup>2</sup> x 810 mm.
DN400	2 lines of 10 mm <sup>2</sup> x 928 mm.	1 line of 10 mm <sup>2</sup> x 928 mm.
DN450	2 lines of 10 mm <sup>2</sup> x 1028 mm.	1 line of 10 mm <sup>2</sup> x 1028 mm.
DN500	2 lines of 14 mm <sup>2</sup> x 1144 mm.	1 line of 14 mm <sup>2</sup> x 1144 mm.
DN600	2 lines of 14 mm <sup>2</sup> x 1346 mm.	1 line of 14 mm <sup>2</sup> x 1346 mm.

Table 5

 **Note:** If it is not possible to place a rubber joint in the middle another packing line should be used instead.

### LUBRICATION

It is recommended to lubricate the stem twice a year by removing the protection cap and filling it with grease up to half its volume.



After the maintenance and in an ATEX zone, you must check the electrical continuity between the pipe and the rest of the valve's components, such as the body, gate, stem... EN 12266-2 Standard, annex B, points B.2.2.2. and B.2.3.1.)

## KNIFE-GATE VALVES

## F SERIES

### MAINTENANCE OF THE PNEUMATIC ACTUATOR

The pneumatic cylinders in our valves are manufactured and assembled at our premises. The maintenance of these cylinders is simple, if your need to replace any elements and you have any questions please consult **C.M.O.**. Below is an exploded diagram of the pneumatic actuator and a list of the cylinder's components. The top cover and the support cover are usually made of aluminium, but from pneumatic cylinders greater than  $\varnothing 200$  mm, they are made of cast iron GJS-400.

The maintenance kit normally includes: The socket and its joints and the scraper, and if the customer wishes the piston is also supplied. Below we show the steps to follow to replace these parts.

1. Position the valve in closed position and shut off the pneumatic circuit pressure.
2. Loosen the cylinder air input connections.
3. Release and remove the cylinder cap (5), the cylinder tube (4) and the tie rods (16).
4. Loosen the nut (14) which connects the piston (3) and the rod (1), remove the parts. Disassemble the cir-clip (10) and remove socket (7) with its joints (8,9) .
5. Release and remove the cylinder head (2), in order to remove the scraper (6).
6. Replace the damaged parts with new ones and assemble the actuator in the opposite order to that described for the disassembly.

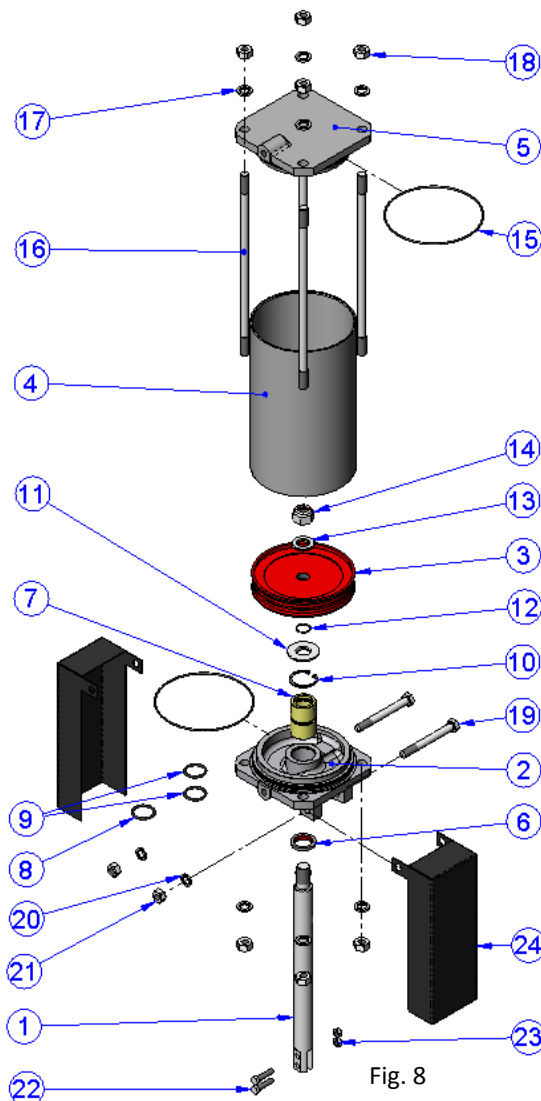

PNEUMATIC ACTUATOR		
POS.	DESCRIPTION	MATERIAL
1	STEM	AISI-304
2	CYLINDER HEAD	ALUMINIUM
3	PISTON	S275JR + EPDM
4	CYLINDER	ALUMINIUM
5	CYLINDER CAP	ALUMINIUM
6	SCRAPER	NITRILE
7	SOCKET	NYLON
8	OUTSIDE O-RING	NITRILE
9	INSIDE O-RING	NITRILE.
10	CIR-CLIP	STEEL
11	WASHER	ST ZINC
12	O-RING	NITRILE.
13	WASHER	ST ZINC
14	SELF-LOCKING NUT	5.6 ZINC
15	O-RING	NITRILE.
16	TIE RODS	F-114 ZINC
17	WASHER	ST ZINC
18	NUT	5.6 ZINC
19	SCREW	5.6 ZINC
20	WASHER	ST ZINC
21	NUT	5.6 ZINC
22	SCREW	A-2
23	SELF-LOCKING NUT	A-2
24	PROTECTION	S275JR

Table 6

C.M.O.

Amategui Aldea 142, 20400 Txarama-Tolosa (SPAIN)

MAN-F.EN04

Tel. National: 902.40.80.50 Fax: 902.40.80.51 / Tel. International: 34.943.67.33.99 Fax: 34.943.67.24.40

cmo@cmo.es <http://www.cmo.es>

Page 10

# KNIFE-GATE VALVES

# F SERIES

## STORAGE

To ensure the valve is in optimum conditions of use after long periods of storage, it should be stored in a well-ventilated place at temperatures below 30°C.

It is not advisable, but if it is stored outside, the valve must be covered to protect it from heat and direct sunlight, with good ventilation to prevent humidity. The following aspects must be considered for storage purposes:

- The storage place must be dry and under cover.
- It is not recommended to store the equipment outdoors with direct exposure to adverse weather conditions, such as rain, wind, etc. Even less so if the equipment is not protected with packaging.
- This recommendation is even more important in areas with high humidity and saline environments. Wind can carry dust and particles which can come into contact with the valve's mobile parts and this can lead to operating difficulties. The actuator system can also be damaged due to the introduction of particles in the different elements.
- The equipment must be stored on a flat surface to avoid deformations.
- If the equipment is stored without suitable packaging it is important to keep the valve's mobile parts lubricated, for this reason, it is recommended to carry out regular checks and lubrication.
- Likewise, if there are any machined surfaces without surface protection it is important for some form of protection to be applied to prevent the appearance of corrosion.

## COMPONENTS LIST (Manual Valve)

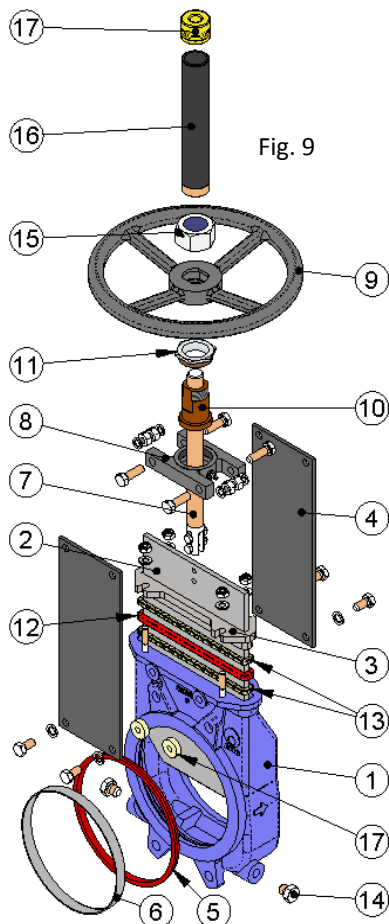

COMPONENT LIST	
POS	DESCRIPTION
1	BODY
2	GATE
3	PACKING GLAND
4	SUPPORT PLATE
5	O-RING
6	RING
7	STEM
8	YOKE
9	HANDWHEEL
10	STEM NUT
11	STOP NUT
12	SEAL (PACKING)
13	PACKING
14	LOWER CAP (OPTIONAL)
15	HOOD NUT
16	HOOD
17	CAP

Table 7

C.M.O.

Amategui Aldea 142, 20400 Txarama-Tolosa (SPAIN)

MAN-F.EN04

Tel. National: 902.40.80.50 Fax: 902.40.80.51 / Tel. International: 34.943.67.33.99 Fax: 34.943.67.24.40

cmo@cmo.es <http://www.cmo.es>

Page 11