

# GA



---

## INSTRUCTIONS AND MAINTENANCE MANUAL - SERIE GA

---

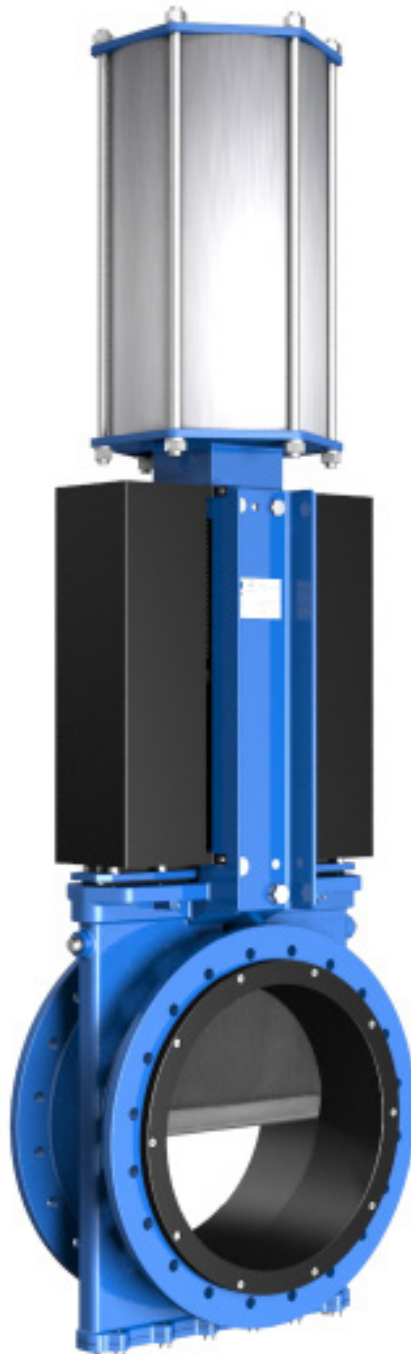

# INSTRUCTIONS AND MAINTENANCE MANUAL - SERIE GA

## ASSEMBLY

### DIRECTIVAS

Pressure Equipment Directive:

**(PED) ART 4.3 /CAT.1**

Potential Explosive Atmospheres Directive (optional):

**(ATEX) CAT.3 ZONE 2 y 22 GD.**



The **GA** Valve complies with the Directive on Equipment and Protective Systems for Potentially Explosive Atmospheres. In these cases the logo will appear on the identification label. This label shows the exact classification of the zone in which the valve can be used. The user is responsible for its use in any other zone.

### HANDLING

When handling the equipment please pay special attention to the following points:

- **SAFETY WARNING:** Before handling the valve check that the crane to be used is capable of bearing its weight.

- Do not lift the valve or hold it by the actuator. Lifting the valve by the actuator can lead to operating problems as it is not designed to withstand the valve's weight.

- Do not lift the valve by holding it in the flow passage area. The valve's O-ring seal is located in this area. If the valve is held and lifted by this area it can damage the surface and the O-ring seal and lead to leakage problems whilst the valve is operating.



- To prevent damage, especially to the anticorrosive protection, it is recommended to use soft straps to lift the CMO knife gate valves. These straps must be fitted around the top of body.

- Packing in wooden boxes: If the equipment is packed in wooden boxes these must be provided with clearly marked holding areas where the slings will be placed when securing them. In the event that two or more valves are packed together, separation and securing elements must be provided between them to prevent possible movements, knocks and friction during transport. When storing two or more valves in the same box you must ensure they are correctly supported to prevent deformations. In the case of dispatches by sea we recommend the use of vacuum bags inside the boxes to protect the equipment from contact with sea water.

- Pay special attention to maintaining the correct levelling of the valves during loading and unloading as well as during transport to prevent deformations in the equipment. For this purpose we recommend the use of mounts or trestles.

### INSTALLATION

In order to avoid personal harm and other type of damage (to the facilities, the valve, etc.) please follow these instructions:

- The staff responsible for the installation or operation of the equipment must be qualified and trained.
- Use suitable Personal Protective Equipment (PPE) (gloves, safety boots, goggles...).
- Shut off all lines that affect the valve and put up a warning sign to inform about the work being performed.
- Completely isolate the valve from the whole process. Depressurise the process.
- Drain all the line's fluid through the valve.
- Use hand tools not electric tools during the installation and maintenance, in accordance with **EN13463-1 (15)**.

Before installation, inspect the valve to ensure no damage has occurred during transport or storage.

Make sure that the inside of the valve's body and, in particular the seal area, are clean. Inspect the installation's pipes and the flanges to make sure they are clean.



**IMPORTANT:** The valve must always be installed in the OPEN position.



## VENTAJAS

### ASPECTS TO BE CONSIDERED DURING ASSEMBLY

- As the **GA** valve is bi-directional, the direction of the fluid does not matter, it works correctly in both directions.
- Special care must be taken to respect the correct distance (gap) between the flanges and ensure they are correctly aligned and parallel (Fig. 1).

The incorrect position or installation of the flanges can cause deformations on the valve's body and this could lead to operating problems.

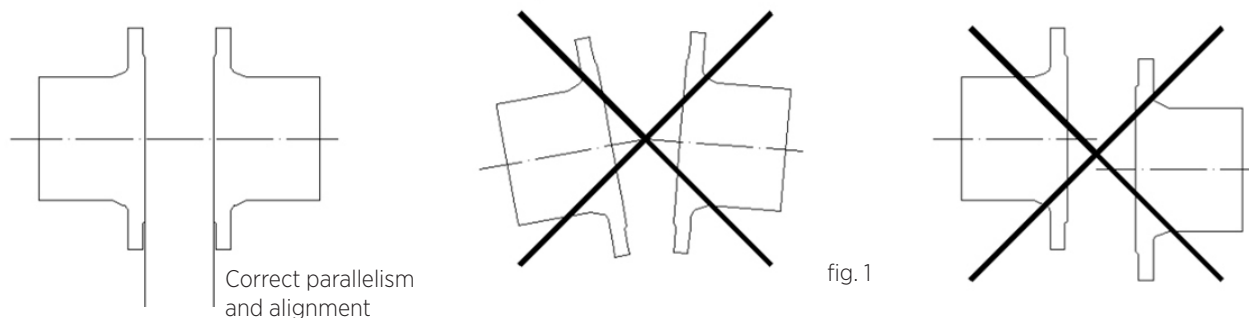

It is very important to make sure that the valve is correctly aligned and parallel to the flanges to prevent leakages and avoid deformations. Ensure the valve is assembled in open position.

- The screws in the tapped blind holes will have a maximum depth (Fig. 2) and will never reach the bottom of the hole. The following table (Table 1) shows the maximum thread depth in the holes and the maximum torque to be applied to the flange screws:

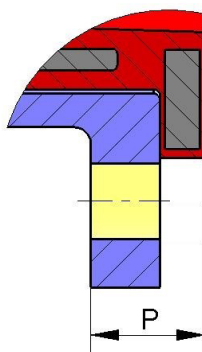

DN	50	65	80	100	125	150	200	250	300	350	400	450	500	600	700	750	800	900	1000	1100	1200	1300	1400	1500
P	32	32	32	32	32	32	33	35	37	37	41	45	46	49	56	58	59	62	69	72	74	80	81	82
PAR Nm	45	45	45	45	45	88	88	88	88	88	152	152	152	223	223	303	303	303	412	412	529	529	685	1414

Tabla. 1

- The equipment must be firmly installed in the pipe. It will be joined to the pipe with a screw joint.
- The screws and nuts to be fitted must also be suitable for the operating conditions and their measurements must be in accordance with the approved plans. The screws and nuts must be fitted diametrically.

To torque to apply to the fastening screws and nuts must be correct according to the applicable standard, we recommend the initial assembly be carried out with a low tightening torque and after all the screws are in place, the final torque is applied.

- As regards scaffolding, ladders and other auxiliary elements to be used during the assembly, follow the safety recommendations indicated in this dossier.
- Once the equipment has been assembled make sure that there are no elements, whether interior or exterior, which can interfere with the gate valve's movement.
- Make the relevant connections (electrical, pneumatic, hydraulic) in the equipment's drive system following the instructions and wiring diagrams supplied it.
- The operation of the equipment must be coordinated with the site's control and safety staff and no modifications are permitted in the equipment's external indication elements (limit switches, positioners, etc.).
- When operating the equipment follow the safety recommendations indicated in this dossier.

### ASSEMBLY POSITIONS (Horizontal Pipe)

In horizontal pipes it is recommended that CMO valves be assembled in vertical position, although other assembly positions are also possible.

**Position 1:** This is the most advisable position.

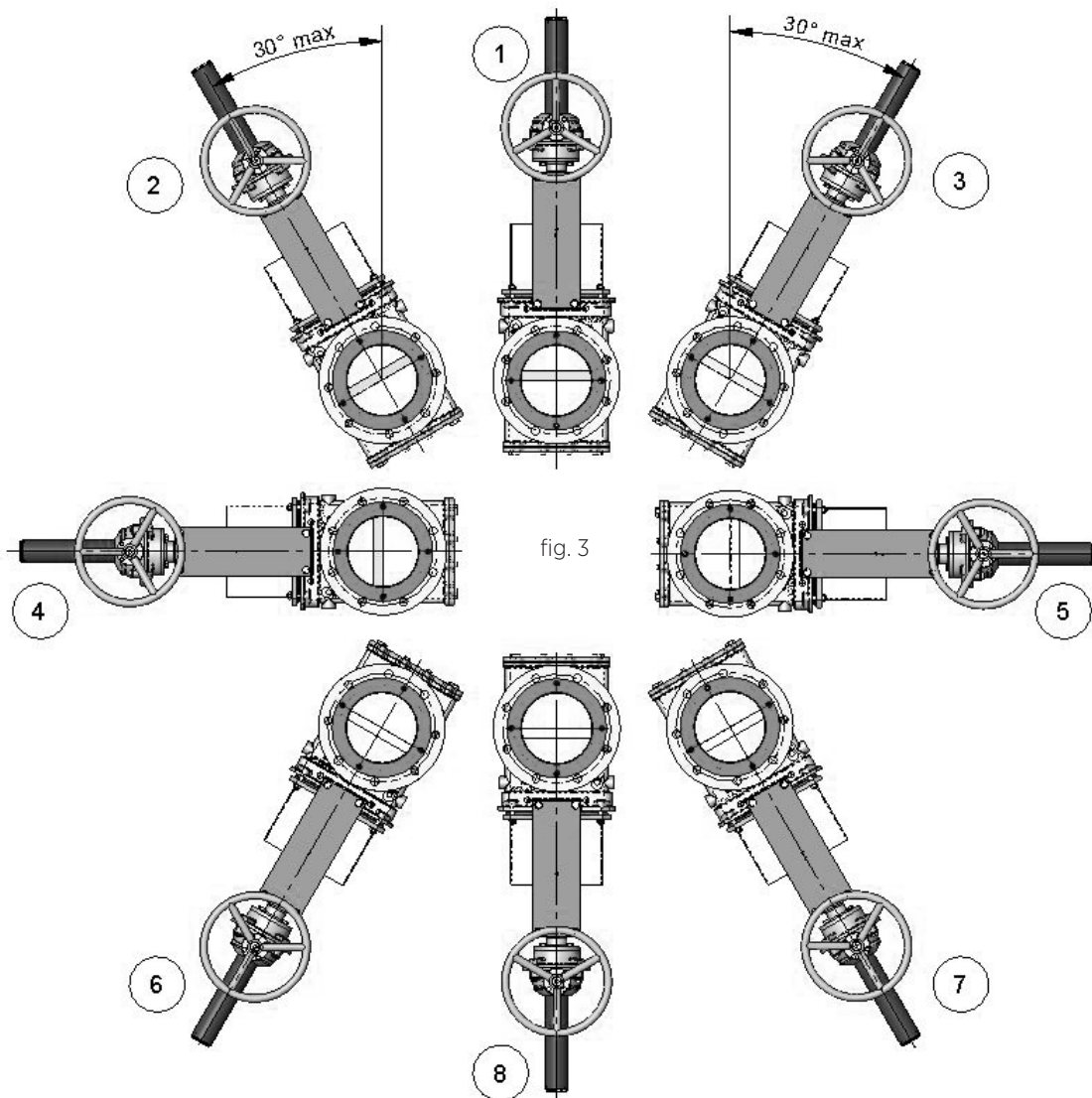

**Position 8:** The valve can be installed in this position but you are advised to contact **CMO Valves** if this is necessary.

**Positions 2, 3, 6 y 7:** For large valves (more than ND300), the maximum angle with the installation vertical is 30°. For smaller sizes the angle can be increased up to 90° (positions 4 and 5).

When it is necessary to install large valves in any of these positions, it is recommended to consult **CMO Valves**, as in these cases, due to the weight of the actuator, a suitable support must be made to prevent deformations and operating problems in the valves.

**Positions 4 y 5:** For smaller sized valves, the valves can be installed in these positions.

To install larger valves (more than ND300) in any of these positions, please contact.. In these cases, due to the weight of the actuator, a suitable support must be made to prevent deformations and operating problems in the valves.

### ASSEMBLY POSITIONS (Vertical/Inclined Pipe)

**CMO valves** can be assembled in all positions; however, certain aspects must be taken into account:

**Positions 1,2 y 3:** In these positions, it is recommended to make a suitable support, because, due to the weight of the actuator, deformations may arise and this can lead to operating problems in the valves.

Once the valve has been installed, check that all the screws and nuts have been correctly tightened and that the whole valve action system has been correctly adjusted (electrical connections, pneumatic connections, instruments...).

All CMO valves are tested at its facilities, however, during the handling and transport the screws on the packing gland can come loose and must be re-tightened. Once the valve is installed in the pipeline and it has been pressurised, it is very important to check for any leakages from the packing gland to the atmosphere.

In the event of a leakage, tighten the nuts on the packing gland crosswise until the leakage stops, ensuring that there is no contact between the packing gland and the gate.

A very high tightening torque on the packing gland's nuts can lead to problems, such as an increase in the valve's torque, reduction in the packing's working life, or the breaking of the packing gland. The tightening torques are indicated in Table 2:

Once the valve is installed in its place, check that the flanges and electrical and pneumatic connections are secure. If the valve has electrical accessories or you are in an ATEX zone, earth connections must be made before operating it.

If you are in an ATEX zone, check the continuity between the valve and the pipeline (EN 12266-2, annex B, points B.2.2.2. and B.2.3.1.). Check the pipeline's earth connection and the conductivity between the outlet and inlet pipelines

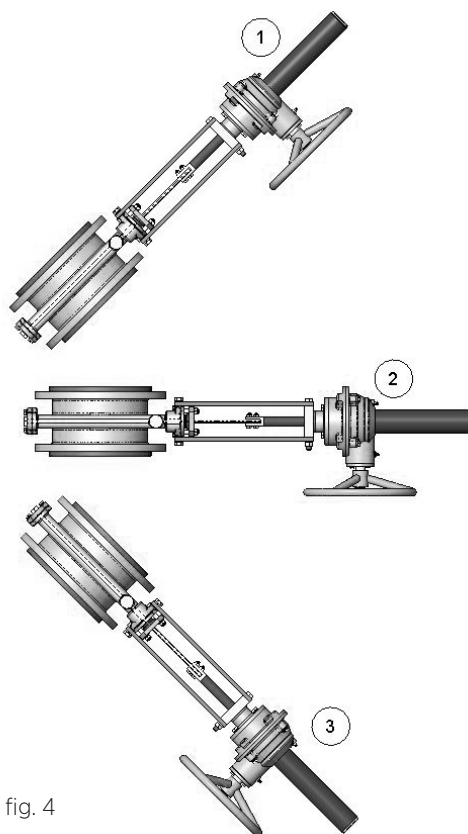

fig. 4

#### TIGHTENING TORQUES FOR PACKING GLAND SCREWS

ND50 a ND125	25 Nm
ND150 a ND300	30 Nm
ND350 a ND1400	55 Nm

Table. 2



## ACTUATOR

### HANDWHEEL (Rising or Non-Rising Stem and Stem with Gear Box)

To operate the valve: Turn the handwheel clockwise to close or anticlockwise to open.

### CHAINWHEEL

To operate the valve pull one of the chain's vertical drops, taking into account that locking is carried out when the chainwheel turns clockwise.

### LEVER

First loosen the position locking clamp located on the yoke. Once it is unlocked raise the lever to open or lower it to close. To complete the operation lock the lever again.

### PNEUMATIC (Double and Single Acting)

CMO pneumatic actuators are designed to be connected to a 6 kg/cm<sup>2</sup> pneumatic network, although these cylinders support up to 10 kg/cm<sup>2</sup>. The pressurised air used for the pneumatic actuator must be correctly filtered and lubricated. This type of actuator does not require any adjustment, due to the fact that the pneumatic cylinder is designed for the exact stroke required by the valve

### HIDRAULIC

CMO hydraulic actuators are designed to work at a standard pressure of 135 kg/cm<sup>2</sup>. This type of actuator does not require any adjustment, due to the fact that the hydraulic cylinder is designed for the exact stroke required by the valve.

### MOTORISED (Rising or Non-Rising Stem)

If the valve incorporates a motorised actuator it will be accompanied with the electric actuator supplier's instructions.

## MAINTENANCE

If the valves suffer any damage due to improper handling or without the proper authorisation, **CMO Valves** will not be responsible. The valves must not be modified except under express authorisation.

- Use suitable Personal Protective Equipment (PPE) (gloves, safety boots, goggles...).
- Shut off all lines that affect the valve and put up a warning sign to inform about the work being performed.
- Completely isolate the valve from the whole process. Depressurise the process.
- Drain all the line's fluid through the valve.
- Use hand tools not electric tools during the maintenance, in accordance with EN13463-1(15).

The only maintenance required in this type of valve is to change the packing's rubber joint and the rubber seals. It is recommended to carry out regular checks on the sleeves. The duration of these seals will depend on the valve's working conditions, such as: Pressure, temperature, number of operations, type of fluid and others.

In an ATEX zone, electrostatic charges may be present inside the valve, which can cause a risk of explosion. The user will be responsible for carrying out the appropriate actions in order to minimise the risks.

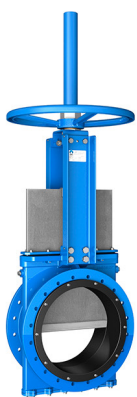

Handwheel with rising stem



Pneumatic actuator



Hydraulic actuator

fig. 5



Electric-motor actuator



Handwheel with gearbox

The maintenance staff must be informed about the risks of explosion and ATEX training is recommended. If the fluid transported constitutes an internal explosive atmosphere, the user must regularly check the installation's correct watertight integrity. Regular cleaning of the valve to prevent accumulation of dust. Assemblies not permitted at the end of the line. Avoid re-painting the products supplied.

### LUBRICATION

It is recommended to lubricate the stem twice a year by removing the protection cap and filling it with grease up to half its volume.

After the maintenance and in an ATEX zone, you must check the electrical continuity between the pipe and the rest of the valve's components, such as the body, gate, stem... EN 12266-2 Standard, annex B, points B.2.2.2. and B.2.3.1.)

### IMPORTANT SAFETY ASPECTS

- In order to work under ideal safety conditions, the magnetic and electrical elements must be in idle mode and the air tanks depressurised. The electrical control cabinets must also be out of service. The maintenance staff must be up to date with the safety regulations and work can only start under orders from the site's safety staff.
- The safety areas must be clearly marked and you must avoid placing auxiliary equipment (ladders, scaffolding, etc.) on levers or mobile parts which will lead to the movement of the gate valve.
- In equipment with spring return actuators, the gate must be mechanically locked and only unlocked when the actuator is pressurised.
- In equipment with electrical actuator, it is recommended to disconnect it from the mains in order to access the mobile parts without any risk.
- Due to its great importance, you must check that the valve's axle has no load before disassembling the actuator system.

Taking into account the recommendations indicated, below we indicate the maintenance operations carried out in this type of equipment:

## REPLACING THE SEALING JOINT

1. Make sure there is absolutely no pressure and fluid in the installation.
2. Remove the valve from the pipeline.
3. Place the gate (2) in open position
4. The sleeves (7) are replaced from outside the valve's body, it is a seat with two symmetrical parts, below we show a diagram of the seat (fig.6)..
5. Once the sleeves have been removed, clean their housing thoroughly.
6. Once they have been lubricated with Vaseline, insert the new sleeves (7) of the same dimensions as those old ones..
7. Replace the valve between the flanges, taking special care not to damage the sleeves.
8. Before starting up the installation, perform various operations to open and close the valve.

## REPLACING THE PACKING SEAL

1. Make sure there is absolutely no pressure and fluid in the installation.
2. Place the valve in closed position.
3. Loosen the screws that connect the stem or rod to the gate
4. Release the connection between the support plates (8) and the body (1).
5. Release and remove the packing gland (3) and the safety guards where present.
6. Remove the old packing seal (4) and greased packing using a pointed tool, taking care not to damage the surface of the gate (2)..
7. Carefully clean the packing and make sure that there are no residues anywhere so that the new greased packing (5) and the packing seal (4) fit correctly.
8. Insert the new greased packing (5) and the new packing seal (4) correctly lubricated, impregnating their inner cavities with plenty of Vaseline.
9. Place the packing gland in its original position (step 5), making sure it does not touch the gate, carefully tighten all the nuts crosswise and make sure the same distance is left between the gate and the packing gland on both sides
10. Screw down the support plates and the stem, in the reverse order to what is described in steps 3 and 4.
11. Perform several manoeuvres with no load, checking the correct operation of the valve and ensuring the packing gland is correctly centred.
12. Pressurise the valve in the line and tighten the packing gland crosswise, enough to prevent leakages to the atmosphere

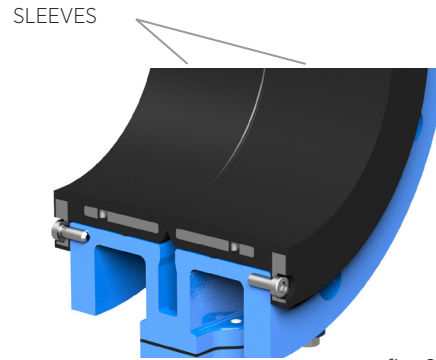

fig. 6

**\*Note:** The numbers in brackets refer to the components list in Table 5

**\*Note:** During the assembly of the new sleeves it is recommended to apply "Vaseline" to the seal to facilitate the assembly process and the valve's correct operation (do not use oil or grease), below in Table 3 we show details of the Vaseline used

WHITE PETROLEUM JELLY		
Saybolt Colour	ASTM D-156	15
Melting point (°C)	ASTM D-127	60
Viscosity at 100°C	ASTM D-445	5
Penetration 25°C mm/10	ASTM D-937	165
Silicone content	None	
Pharmacopeia BP	OK	

Table. 3

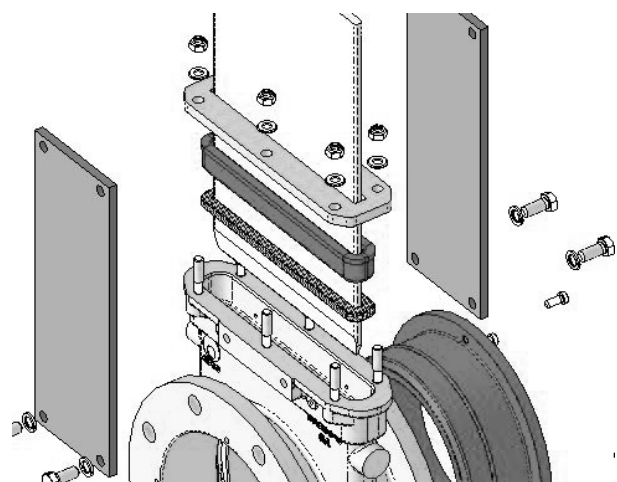

fig. 7

## MAINTENANCE OF THE PNEUMATIC ACTUATOR

The pneumatic cylinders in our valves are manufactured and assembled at our premises. The maintenance of these cylinders is simple, if your need to replace any elements and you have any questions please consult CMO. Below is an exploded diagram of the pneumatic actuator and a list of the cylinder's components. The top cover and the support cover are usually made of aluminium, but from pneumatic cylinders greater than Ø200 mm, they are made of cast iron GJS-400.

The maintenance kit normally includes: The socket and its joints and the scraper, and if the customer wishes the piston is also supplied. Below we show the steps to follow to replace these parts.

1. Position the valve in closed position and shut off the pneumatic circuit pressure.
2. Loosen the cylinder air input connections.
3. Release and remove the cylinder cap (5), the cylinder tube (4) and the tie rods (16).
4. Loosen the nut (14) which connects the piston (3) and the rod (1), remove the parts. Disassemble the cir-clip (10) and remove socket (7) with its joints (8,9).
5. Release and remove the cylinder head (2), in order to remove the scraper (6).
6. Replace the damaged parts with new ones and assemble the actuator in the opposite order to that described for the disassembly.

## STORAGE

To ensure the valve is in optimum conditions of use after long periods of storage, it should be stored in a well-ventilated place at temperatures below 30°C. It is not advisable, but if it is stored outside, the valve must be covered to protect it from heat and direct sunlight, with good ventilation to prevent humidity

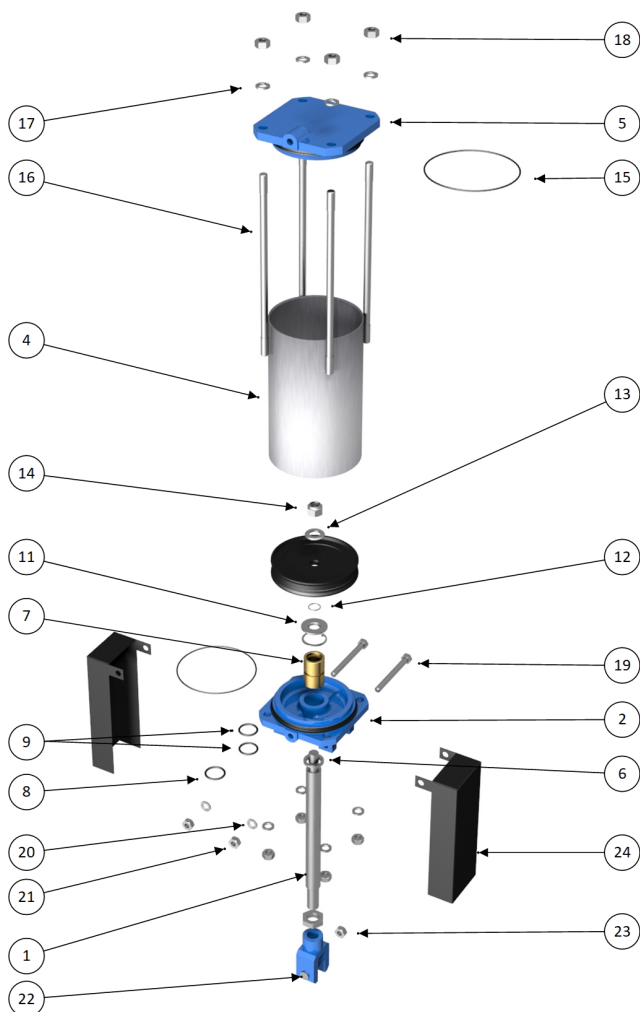

PNEUMATIC ACTUATOR		
POS.	DESCRIPTION	MATERIAL
1	STEM	AISI-304
2	CYLINDER HEAD	ALUMINIO
3	PISTON	S275JR + EPDM
4	CYLINDER	ALUMINIO
5	CYLINDER CAP	ALUMINIO
6	SCRAPPER	NITRILO
7	SLEEVE	NYLON
8	OUTSIDE O-RING	NITRILO
9	INSIDE O-RING	NITRILO
10	CIR-CLIP	ACERO
11	WASHER	ST ZINC
12	O-RING	NITRILO
13	WASHER	ST ZINC
14	SELF-LOCKING NUT	5.6 ZINC
15	O-RING	NITRILO
16	TIE RODS	F-114 ZINC
17	WASHER	ST ZINC
18	NUT	5.6 ZINC
19	SCREW	5.6 ZINC
20	WASHER	ST ZINC
21	SCREW	5.6 ZINC
22	NUT	A-2
23	SELF-LOCKING NUT	A-2
24	PROTECTION	S275JR

Table. 4



The following aspects must be considered for storage purposes:

- The storage place must be dry and under cover.
- It is not recommended to store the equipment outdoors with direct exposure to adverse weather conditions, such as rain, wind, etc. Even less so if the equipment is not protected with packaging.
- This recommendation is even more important in areas with high humidity and saline environments. Wind can carry dust and particles which can come into contact with the valve's mobile parts and this can lead to operating difficulties. The actuator system can also be damaged due to the introduction of particles in the different elements.
- The equipment must be stored on a flat surface to avoid deformations.
- If the equipment is stored without suitable packaging it is important to keep the valve's mobile parts lubricated, for this reason, it is recommended to carry out regular checks and lubrication.
- Likewise, if there are any machined surfaces without surface protection it is important for some form of protection to be applied to prevent the appearance of corrosion.
- Store the valves in open position to ensure that the sleeves are not deformed.

## COMPONENTS LIST

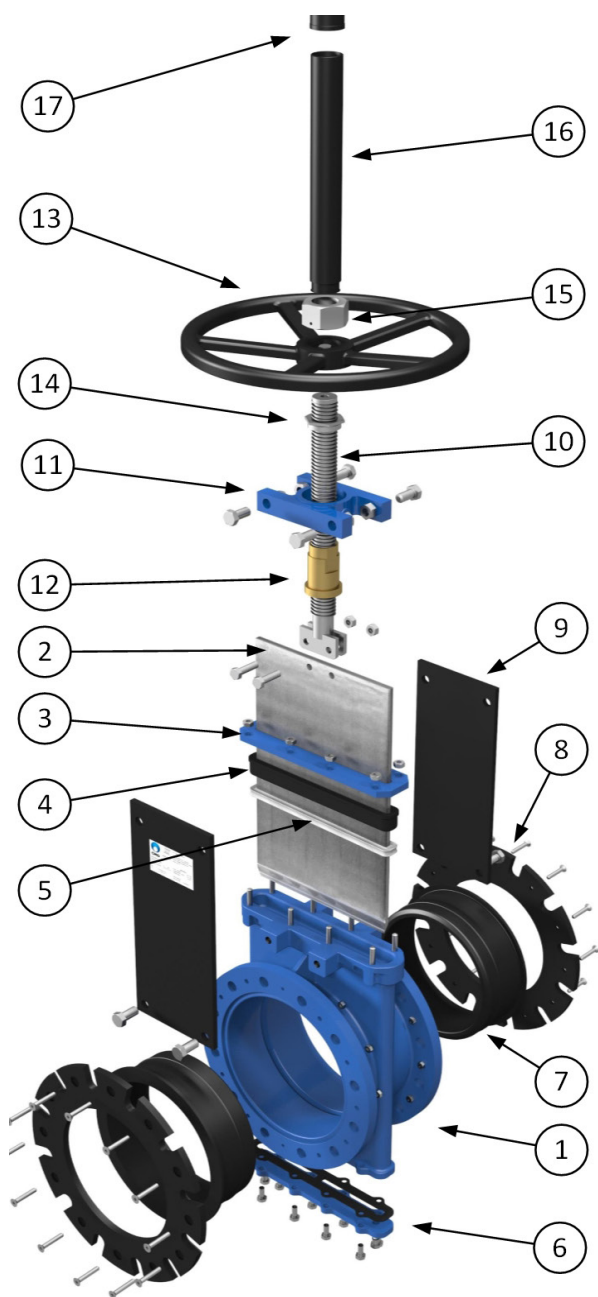

POS.	DESCRIPTION
1	BODY
2	GATE
3	PACKING GLAND
4	JUNTA DE EMPAQUETADURA
5	PACKING SEAL
6	LOWER COVER
7	SLEEVES
8	SUPPORT PLATES
9	STEM
10	YOKE
11	STEM NUT
12	HANDWHEEL
13	STOP NUT
14	HOOD NUT
15	HOOD
16	CAP
17	GREASER (OPTIONAL)

Table. 5

**\*Note:** The numbers in brackets refer to the components list in Table 5.



[www.cmovalves.com](http://www.cmovalves.com)

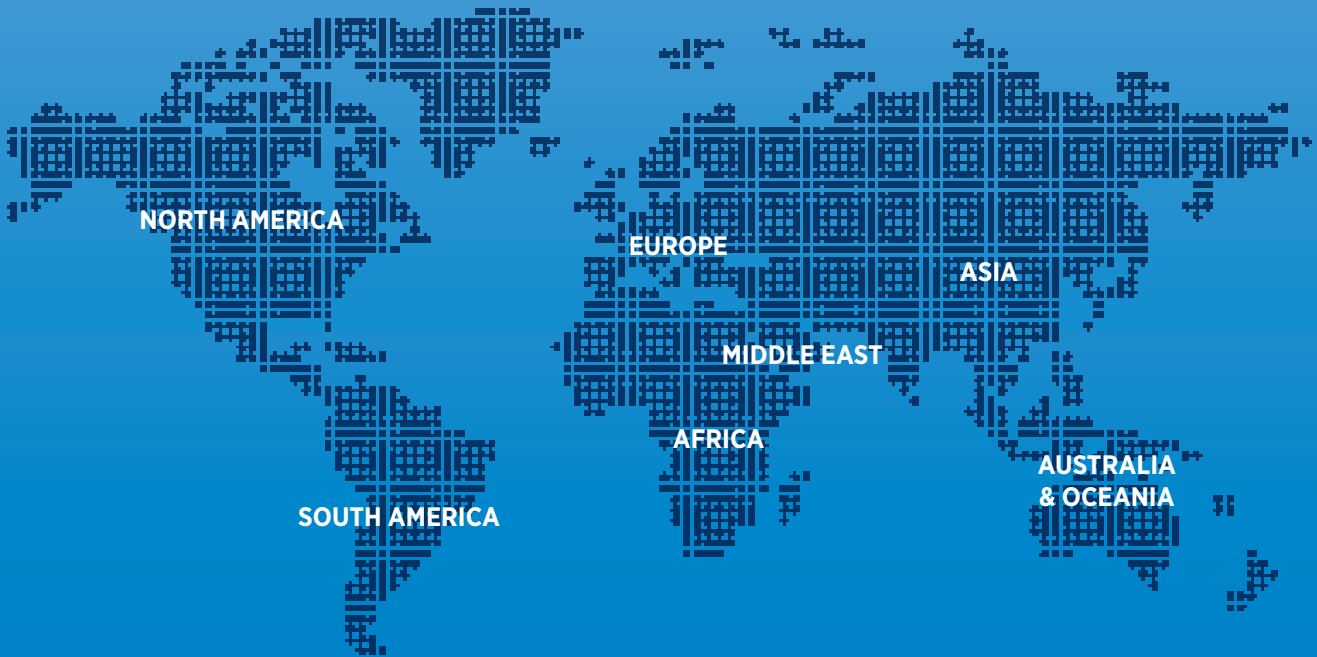

**CMO** VALVES



**CMO HEADQUARTERS  
MAIN OFFICES & FACTORY**

Amategi Aldea, 142  
20400 Tolosa  
Guipuzcoa (Spain)

Tel.: (+34) 943 67 33 99  
Fax: (+34) 943 67 24 40

[cmo@cmovalves.com](mailto:cmo@cmovalves.com)  
[www.cmovalves.com](http://www.cmovalves.com)

**CMO MADRID**

C/ Rumania, 5 - D5 (P.E. Inbisa)  
28802 Alcalá de Henares  
Madrid (Spain)

Tel.: (+34) 91 877 11 80  
Fax: (+34) 91 879 79 94

[cmomadrid@cmovalves.com](mailto:cmomadrid@cmovalves.com)  
[www.cmovalves.com](http://www.cmovalves.com)